

CANTON- μ Proposal:

A Next-Generation Muon $g - 2$ Experiment at Sub-0.1 ppm

Ce Zhang

University of Liverpool

Phipsi 2026 @ PISA



UNIVERSITY OF
LIVERPOOL

LEVERHULME
TRUST

CANTON- μ Proposal:

A Next-Generation Muon $g - 2$ Experiment at Sub-0.1 ppm

- **Lessons** learned from Fermilab $g-2$
- **A recipe** for next-generation muon $g-2$ experiment (e.g. at China's HIAF)
- **Physics reach** at sub-0.1 ppm precision

Many theoretical predictions, yet only *one* precision measurement

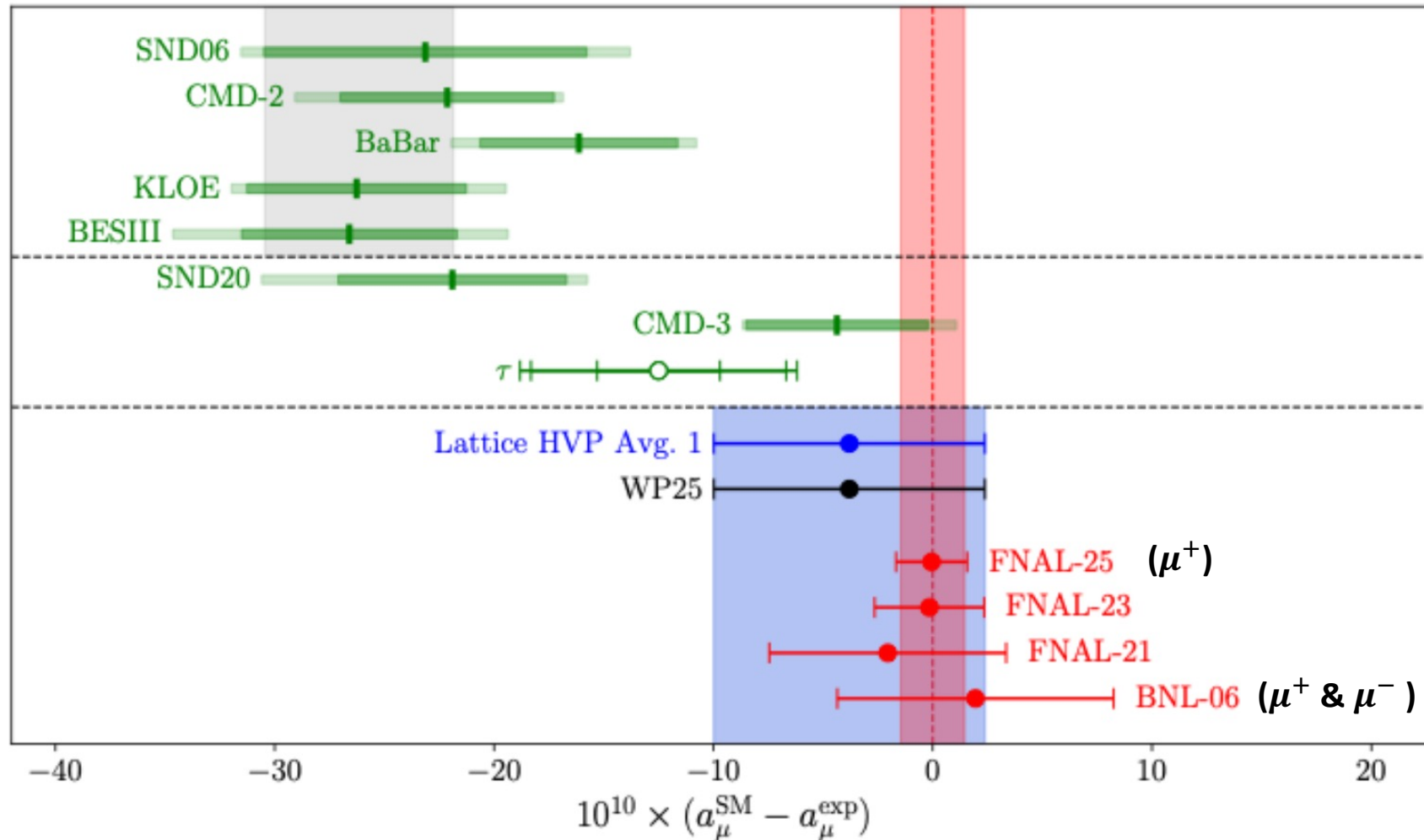

- The theory (WP20/WP25) uncert is about 5 times larger than the exp (0.124 ppm)
- Currently, no approved experiment aims to surpass the Fermilab precision
- Fermilab only measured *positive* muons

Fermilab g-2: the magic- γ approach

- Muon 'g-2' (a_μ) is determined from anomalous spin precession (ω_a) in a magnetic field, but higher-order terms in the BMT equation, due to non-ideal muon motion, must be accounted for:

$$\vec{\omega}_a = -\frac{q}{m} \left[a_\mu \vec{B} - a_\mu \left(\frac{\gamma}{\gamma + 1} \right) (\vec{\beta} \cdot \vec{B}) \vec{\beta} - \left(a_\mu - \frac{1}{\gamma^2 - 1} \right) \frac{\vec{\beta} \times \vec{E}}{c} \right]$$

muon anomalous precession

0 if "in plane"

→ Term cancels at 3.094 GeV/c, the "Magic γ "

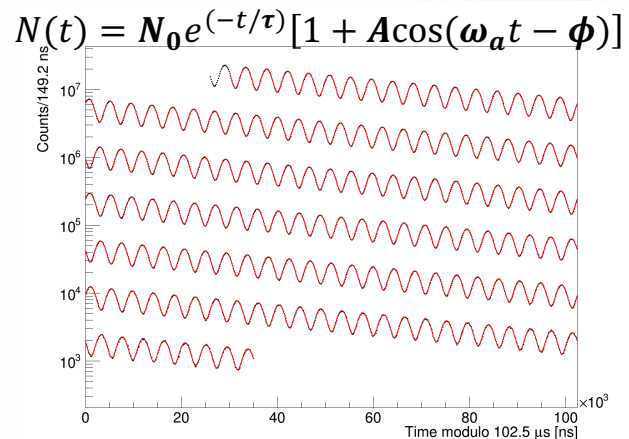

Magic- γ and statistical precision

$$\frac{\Delta\omega_a}{\omega_a} \propto \frac{1}{\gamma BP \sqrt{N}}$$

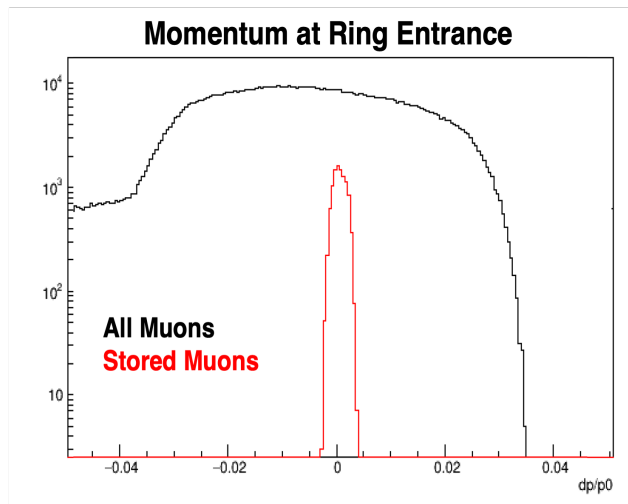

- Fermilab g-2 only stores **2% of incoming muons**
- Due to a very tight acceptance constraint
→ required by the **magic- γ**
- A better muon beam (e.g. lower-emittance muon beam) would be helpful, also giving a smaller oscillations

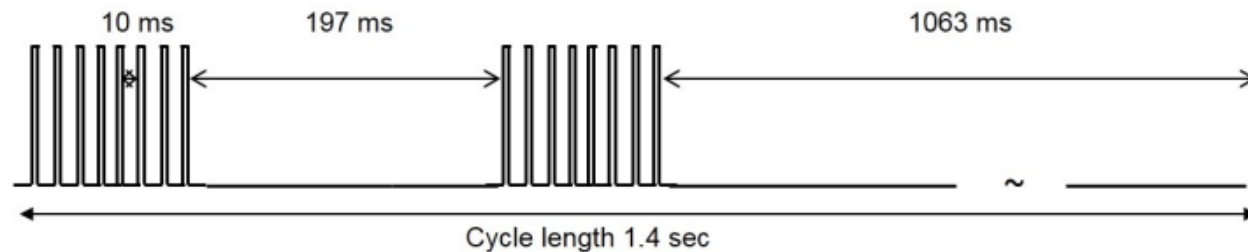

- A better bunching structure also helps, subject to the accelerator constraints

Magic- γ and statistical precision

$$\frac{\Delta\omega_a}{\omega_a} \propto \frac{1}{\gamma B P \sqrt{N}}$$

- A higher γ factor \rightarrow also require relaxing the **magic- γ condition**
- A higher **B-field**
 - compact solenoid (injection would be challenging, ...)
 - one constraint: bunch width < cyclotron period;

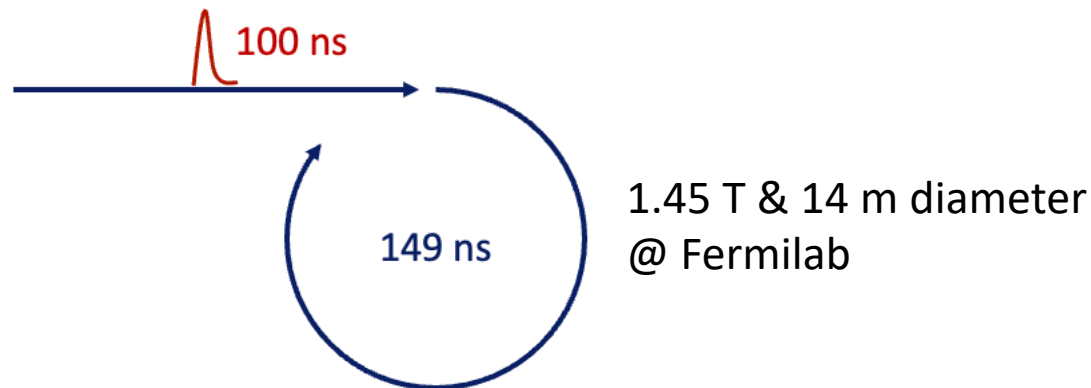

Beyond the magic- γ Paradigm

$$\left(a_\mu - \frac{1}{\gamma^2 - 1} \right) \frac{\vec{\beta} \times \vec{E}}{c}$$

E field 'issue'



'Magic γ '



muon at 3.1 GeV/c
B = 1.45 T



**CERN/BNL/FNAL
Muon g-2**

Reaching the precision limit
(stat \approx syst \sim 100 ppb)

Beyond the magic- γ Paradigm

$$\left(a_{\mu} - \frac{1}{\gamma^2 - 1} \right) \frac{\vec{\beta} \times \vec{E}}{c}$$

E field 'issue'

'Magic γ '

muon at 3.1 GeV/c
B = 1.45 T

Reaching the precision limit
(stat \approx syst \sim 100 ppb)

**CERN/BNL/FNAL
Muon g-2**

remove E-field?

How to focus
(store) muons?

Beyond the magic- γ Paradigm

$$\left(a_{\mu} - \frac{1}{\gamma^2 - 1} \right) \frac{\vec{\beta} \times \vec{E}}{c}$$

E field 'issue'

'Magic γ '

muon at 3.1 GeV/c
B = 1.45 T

Reaching the precision limit
(stat \approx syst \sim 100 ppb)

**CERN/BNL/FNAL
Muon g-2**

remove E-field?

How to focus
(store) muons?

novel muons
(even storable w/o an E field)

J-PARC g-2

novel focusing fields
(capable of focusing
conventional muons)

**New proposals
at HIAF/...**

Concept 1) Hybrid weak focusing

- A hybrid focusing system with E-quadrupoles and B-quadrupoles, using higher-order B fields to compensate for higher-order E-fields:

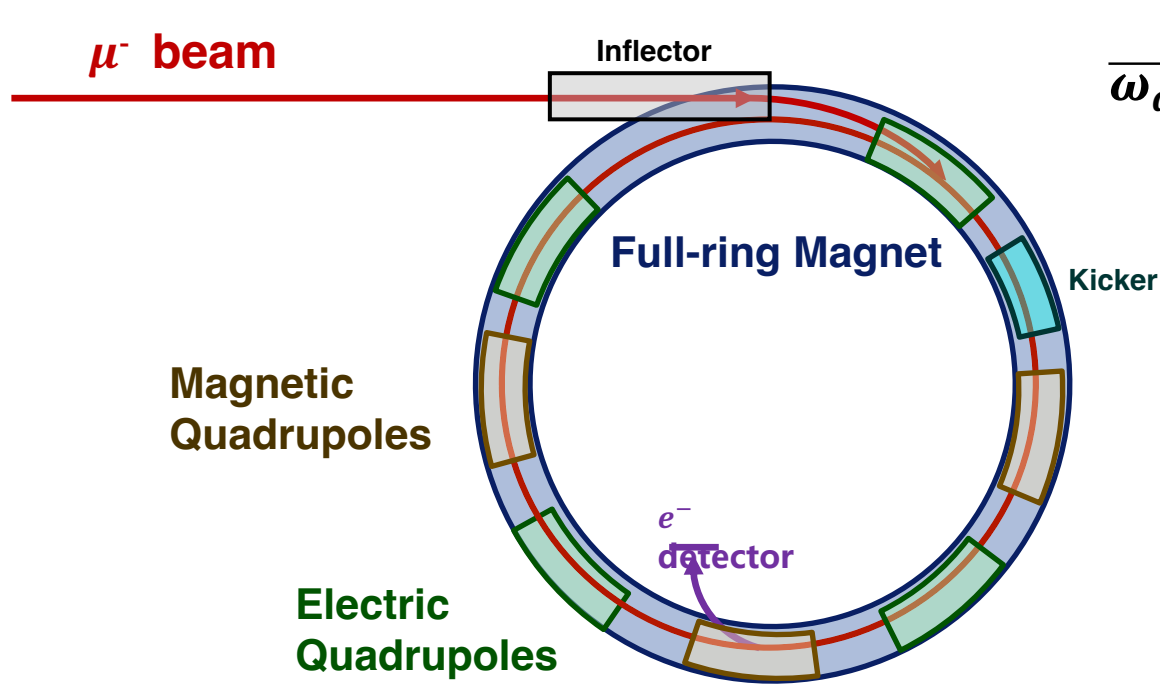

$$\vec{\omega}_a = -\mathbf{a}_\mu \frac{q}{m_\mu} (\vec{B}_0 + \dots) + \frac{q}{m_\mu} \left[\left(\mathbf{a}_\mu - \frac{1}{\gamma^2 - 1} \right) \frac{\vec{\beta} \times \vec{E}}{c} \right]$$

PHYSICAL REVIEW ACCELERATORS AND BEAMS **25**, 024001 (2022)

Analytical estimations of the chromaticity and corrections to the spin precession frequency in weak focusing magnetic storage rings

On Kim^{1,*} and Yannis K. Semertzidis^{1,2}

¹Center for Axion and Precision Physics Research, Institute for Basic Science, Daejeon 34051, Republic of Korea

²Department of Physics, Korea Advanced Institute for Science and Technology, Daejeon 34141, Republic of Korea

(Received 18 October 2021; accepted 8 February 2022; published 18 February 2022)

Concept 1) Hybrid weak focusing

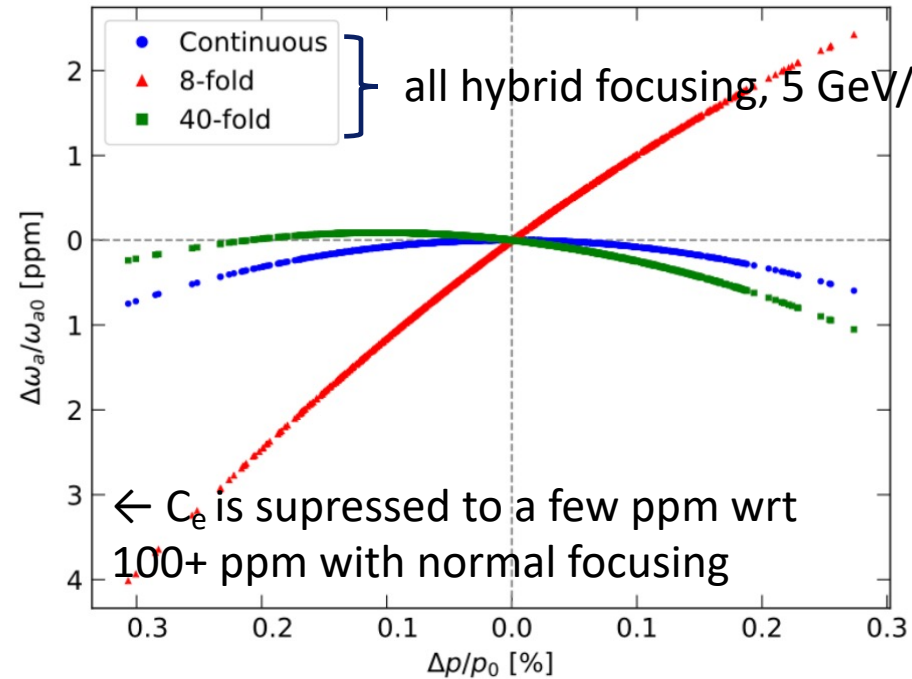
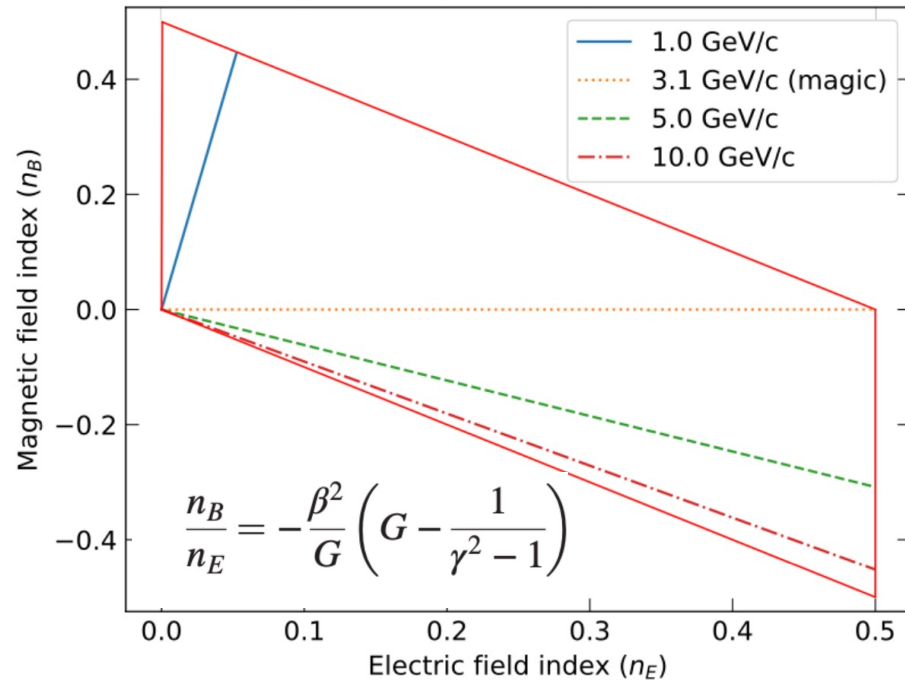

Now all are analytic - will need to demonstrate it works with a more realistic beam dynamics

- In principle it's straightforward to recycle the magnet from FNAL

Concept 2) Proton beam co-magnetometer

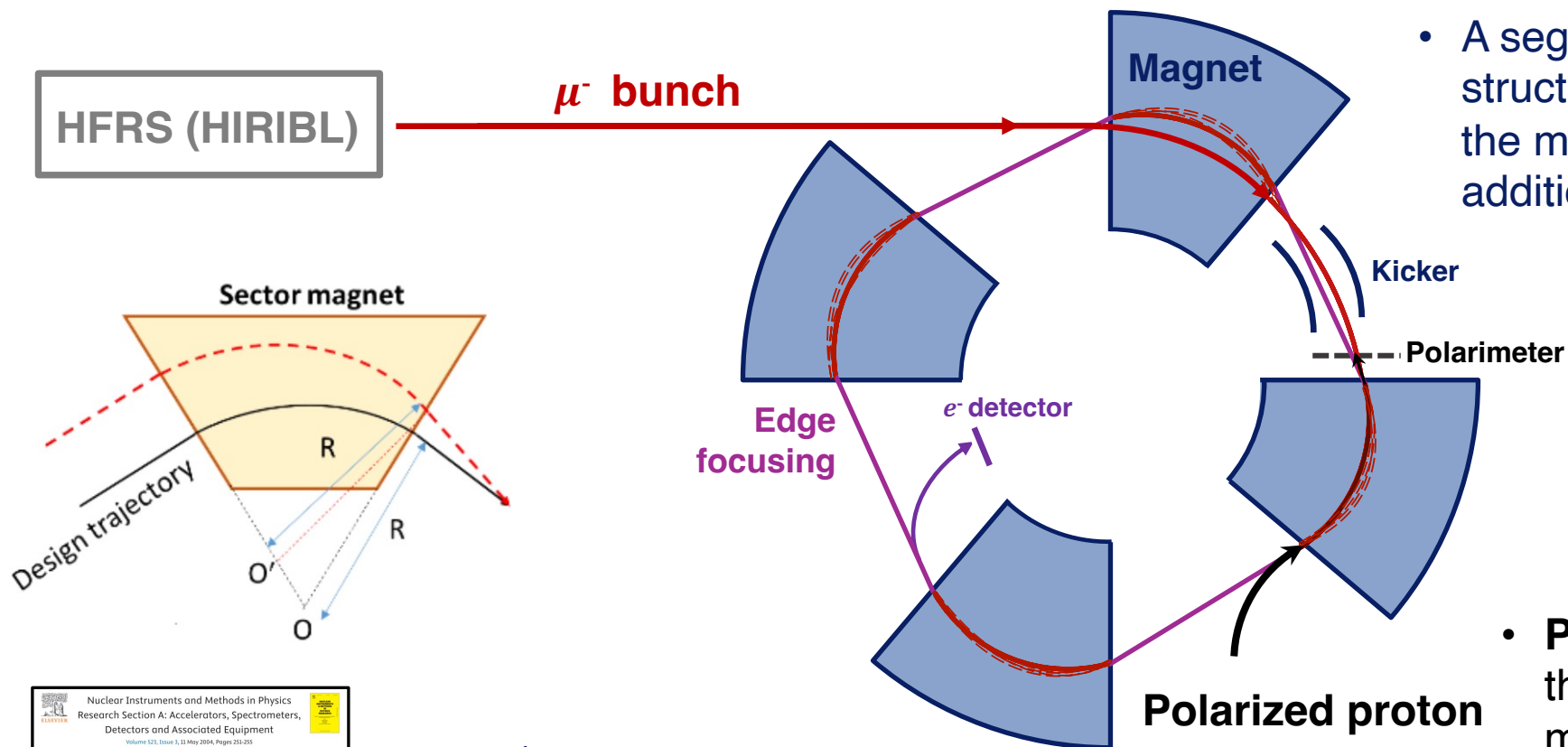

- A segmented **sector magnet** structure with fringe fields to focus the muons, removing the need for additional E field focusing.

- **Polarized protons** experience the same magnetic field as the muons for a direct calibration of the magnetic field.

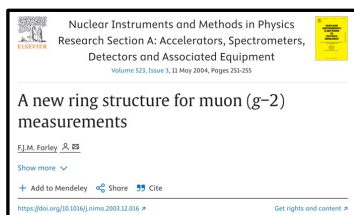

F.J.M. Farley, NIMA,
523 (2004) 251

Concept 2) Proton beam comagnetometer

- No inflector needed → only need to design kicker(s)
- Momentum acceptance is expected to be larger than the magic- γ paradigm
- One big challenge is the edge field calibration
 - Polarized proton beam: essentially a 'denser form' of the NMR probe.
 - Fringe fields with large gradients confined to limited regions where NMR fails

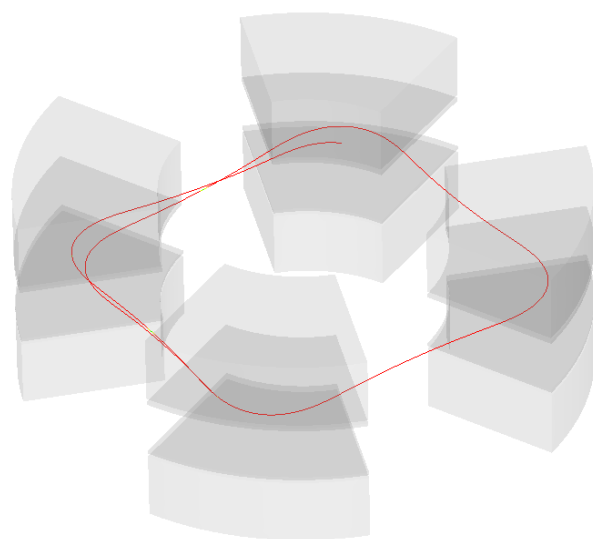
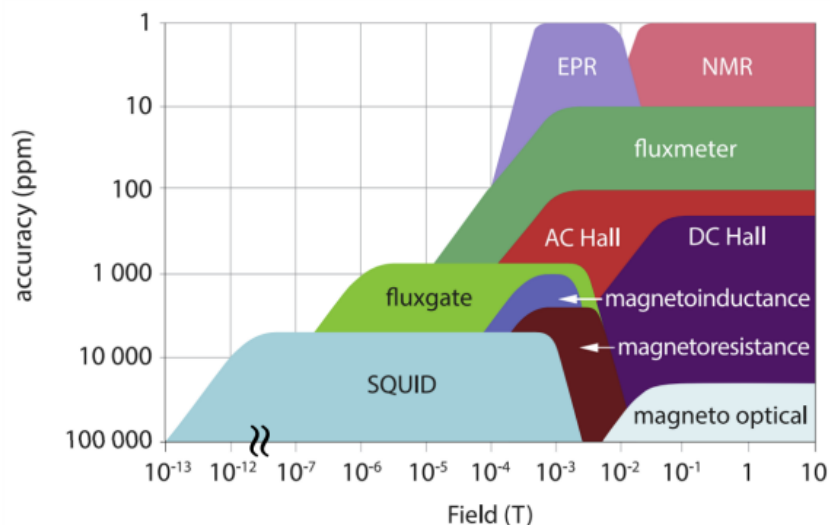

We have started detailed magnet design (Liverpool, IMP), and software development for muon tracking simulation (SJTU, PKU)

← Ideal model constructed with muon tracking simulation

Proposal at China's HIAF

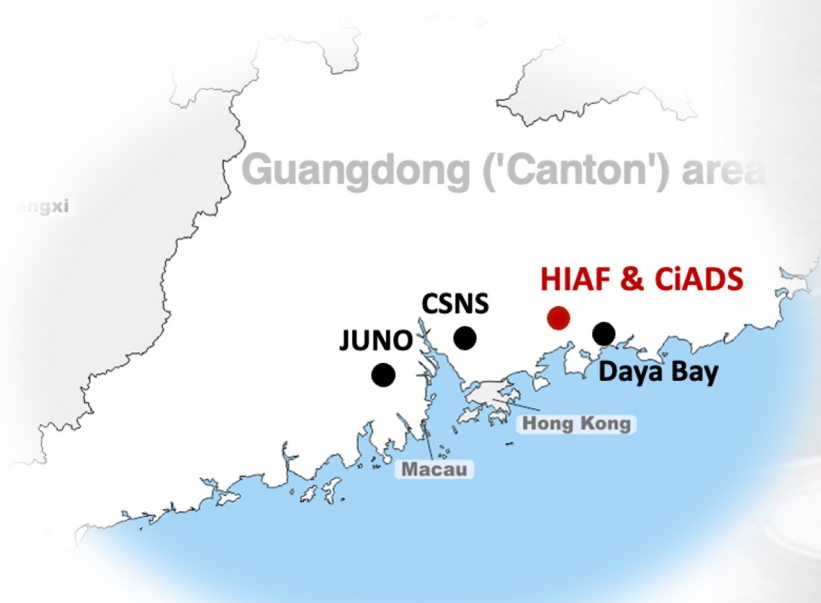

arXiv > hep-ex > arXiv:2512.11486

Search
Help

High Energy Physics – Experiment

[Submitted on 12 Dec 2025]

CANTON- μ Proposal: A Next-Generation Muon $g-2$ Measurement at Sub-0.1 ppm Precision

Ce Zhang, Yu Xu, On Kim, Bingzhi Li, Guodong Shen, Liangwen Chen, Fedor Ignatov, Liang Li, Qiang Li, Xueheng Zhang, Zhiyu Sun

We propose a next-generation precision measurement of the muon anomalous magnetic moment ($g-2$) at the High Intensity Heavy-Ion Accelerator Facility (HIAF) in Huizhou, China. The project, named CANTON- μ (Coherent Anomalous magnetic moment Observation with muon), describes novel experimental approaches based on HIAF's unique capability to produce intense pulsed muon beams at the GeV scale, particularly for negative-muon polarity. These approaches incorporate innovative focusing concepts such as the sector-magnet and weak-focusing ring designs, complemented by advanced magnetic-field calibration methods including a polarized-proton co-magnetometer. This independent measurement with distinct systematics is designed to achieve a precision of 0.1 ppm in Phase 1, matching the latest Fermilab result for μ^+ , and 0.05 ppm in Phase 2 with the HIAF upgrade. Such precision will provide an exceptionally sensitive test of the Standard Model and a powerful probe of New Physics and CPT symmetry.

Comments: 25 pages, 7 figures

Subjects: High Energy Physics – Experiment (hep-ex)

Cite as: arXiv:2512.11486 [hep-ex]

(or arXiv:2512.11486v1 [hep-ex] for this version)

<https://doi.org/10.48550/arXiv.2512.11486>

HIAF

High Intensity heavy-ion Accelerator Facility

Two modes:

- Fast operation: 400 ns bunch length with a repetition rate of 3 Hz
- Slow extraction: 3 sec extraction time with a repetition period of 13 s

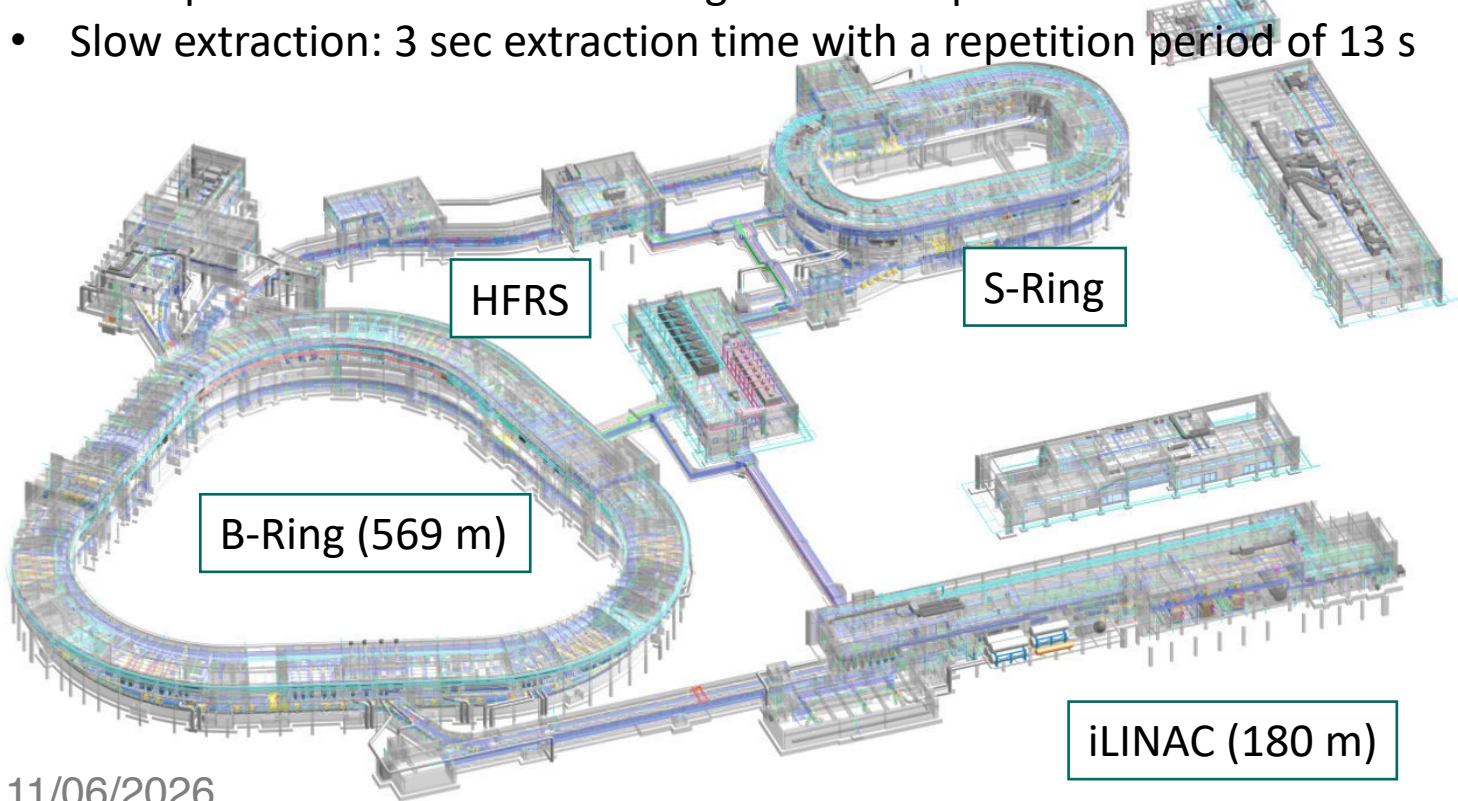

Fast extraction: High-intensity pulsed p/ion

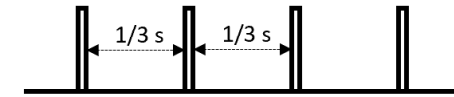

Slow extraction: Quasi-continuous p/ion

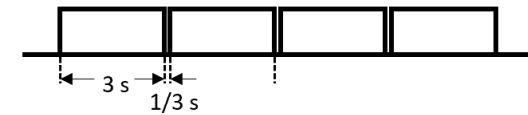

	34Tm, 3Hz	
Ions	Particle per pulse (ppp)	Energy(Ge V/u)
$^{238}\text{U}^{35+}$	1.0×10^{11}	0.84
$^{209}\text{Bi}^{27+}$	1.2×10^{11}	0.85
$^{78}\text{Kr}^{19+}$	3.0×10^{11}	1.7
$^{18}\text{O}^{6+}$	6.0×10^{11}	2.6
Proton	2.0×10^{12}	9.3

Muon beam at HIAF

Very high intensity muon beams for *both* charges

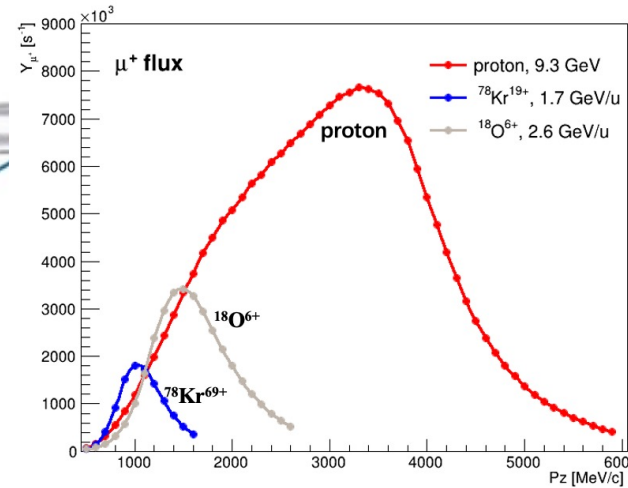
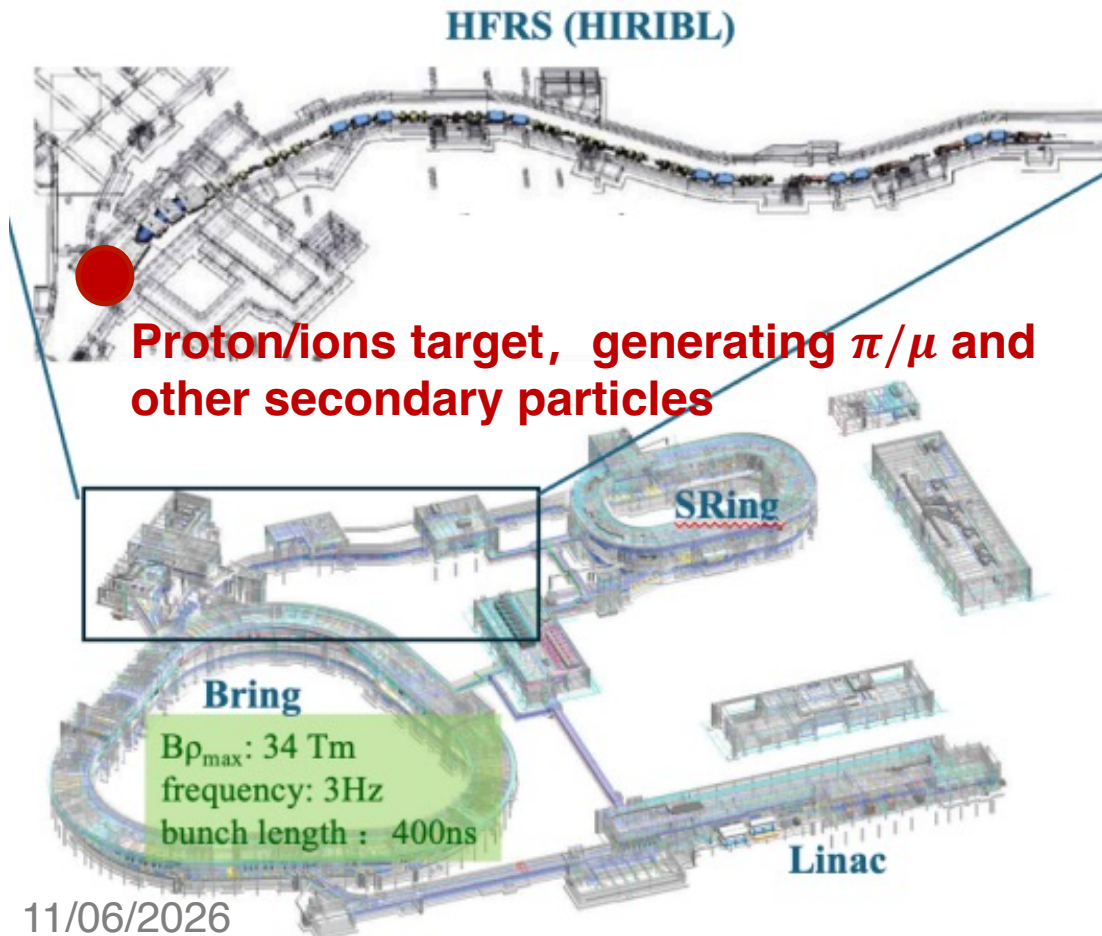

positive muon

- Maximum μ^+ flux: $8.2 \times 10^6/\text{s}$
 - projectile: proton
 - P_z : 3.5 GeV/c

w/ purification: $2.4 \times 10^5/\text{s}$

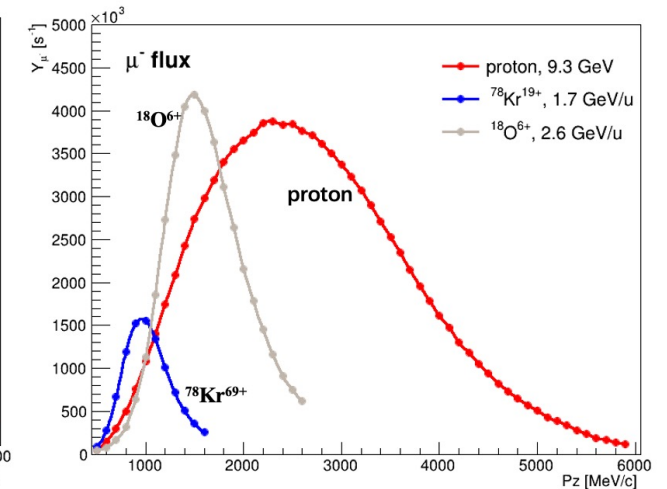

negative muon

- Maximum μ^- flux: $4.2 \times 10^6/\text{s}$
 - projectile: $^{18}\text{O}^{6+}$
 - P_z : 1.5 GeV/c

w/ purification: $3.7 \times 10^5/\text{s}$

HIAF-U

- An upgrade planned for the second phase of HIAF, aims to increase the proton energy from 9 to **25 GeV**, with a dedicated muon beamline in the design.

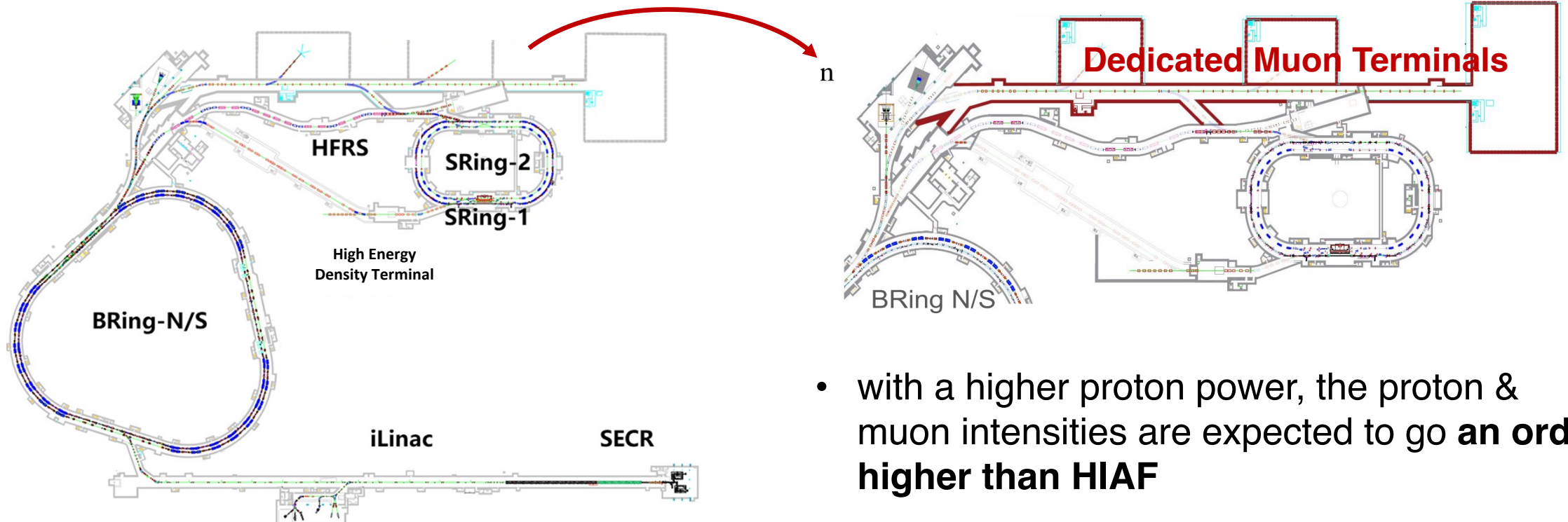

- with a higher proton power, the proton & muon intensities are expected to go **an order higher than HIAF**

Precisions comparison

$$\frac{\Delta\omega_a}{\omega_a} \propto \frac{1}{\gamma B P \sqrt{N}}$$

	FNAL	HIAF	HIAF-U
γ	30	20 – 40 (2-4 GeV)	150 (15 GeV)
B	1.5 T	3 T (planned)	6 – 15 T?
P	~100%	~100%	~100%
N required to achieve the same precision in $\Delta\omega_a/\omega_a$	N	$N/4$	$N/400$
Precision	μ^+ : 0.13 ppm (FNAL) μ^- : 0.7 ppm (BNL)	μ^-/μ^+ : 0.1 ppm	μ^-/μ^+ : 0.05 ppm



The statistical sensitivity won't be a problem at all. Purely systematics-limited
 → opens a lot of interesting possibilities

Next-generation muon g-2 ideas

- The ideas in this talk are also adaptable to other high-intensity GeV muon facilities – CERN, BNL, FNAL...
 - g-2 proposal at PSI: <https://indico.ph.liv.ac.uk/event/2133/>
 - g-2 possibility at BNL with novel polarimetry paradigm (aiming at 1 ppb!): [arxiv 2605.23013](https://arxiv.org/abs/2605.23013)



$(g - 2)_\mu$ Prospects at PSI



- Statistics as in muEDM phase 2 (one year data)

- blue: single muon
- red: 3 muons – how?

- Same magnet, same detector, no electric field
- Prospects with new beamline solenoid to go to $p = 140$ MeV/c

Sensitivity: ~ 0.1 ppm statistically (4 years)

- Collaboration on magnet with JPARC and transport between institutes?

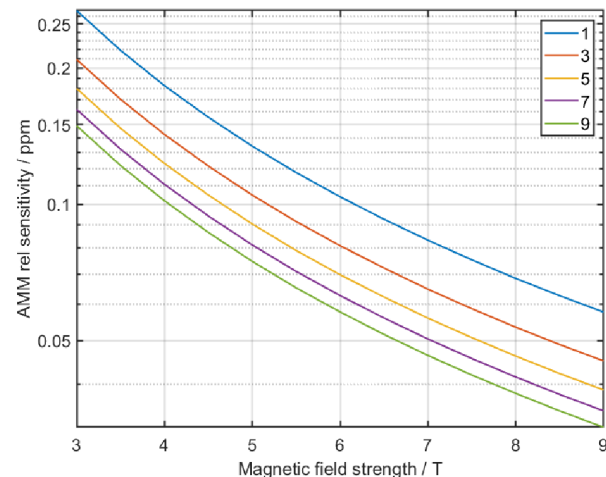

#4 Applications: e.g. a new g-2 experiment

- New proposed experiment on g-2
- Using the AGS 38 GeV we “win” over traditional measurement
 - Accelerate protons in EIC, create pions, capture muons in transfer line to AGS
 - Store muons in AGS
 - By higher momentum (sensitivity goes \sqrt{p})
 - Better measurement of precession
 - Mu+ and Mu- possible
- We use pEDM techniques (spin alignment) to make a precision map of the B-field using protons and deuterons
- New/different systematics
- The experiment can be done and achieve 10ppb with a TRADITIONAL detector (for example see a Liverpool design for Brookhaven)
- **This new experiment (CDR 2026?) will have the potential to get g-2 sensitivity of FNAL in days rather than years. Aim ~ 1 ppb using the COHERENT RESONANCE technique**
 - See the ARXIV

Brookhaven-Liverpool Polarimeter (new design)

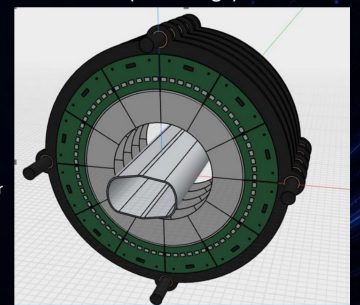

What can we probe given a 0.05 ppm?

1) New-Physics energy scale

- New physics significance depends on the central values from both theory and experiment

$$\Delta a_{\mu}^{\text{Exp-WP2020}} = 26.2(4.5) \times 10^{-10},$$

$$\Delta a_{\mu}^{\text{Exp-WP2025}} = 3.8(6.3) \times 10^{-10}$$

- In the chiral enhancements, scaling behaviour for NP is parameterised as

$$\Delta a_{\mu} \sim R_{\chi} \times \frac{c_{LCR}}{16\pi^2}, \frac{m_{\mu}^2}{\Lambda^2}$$

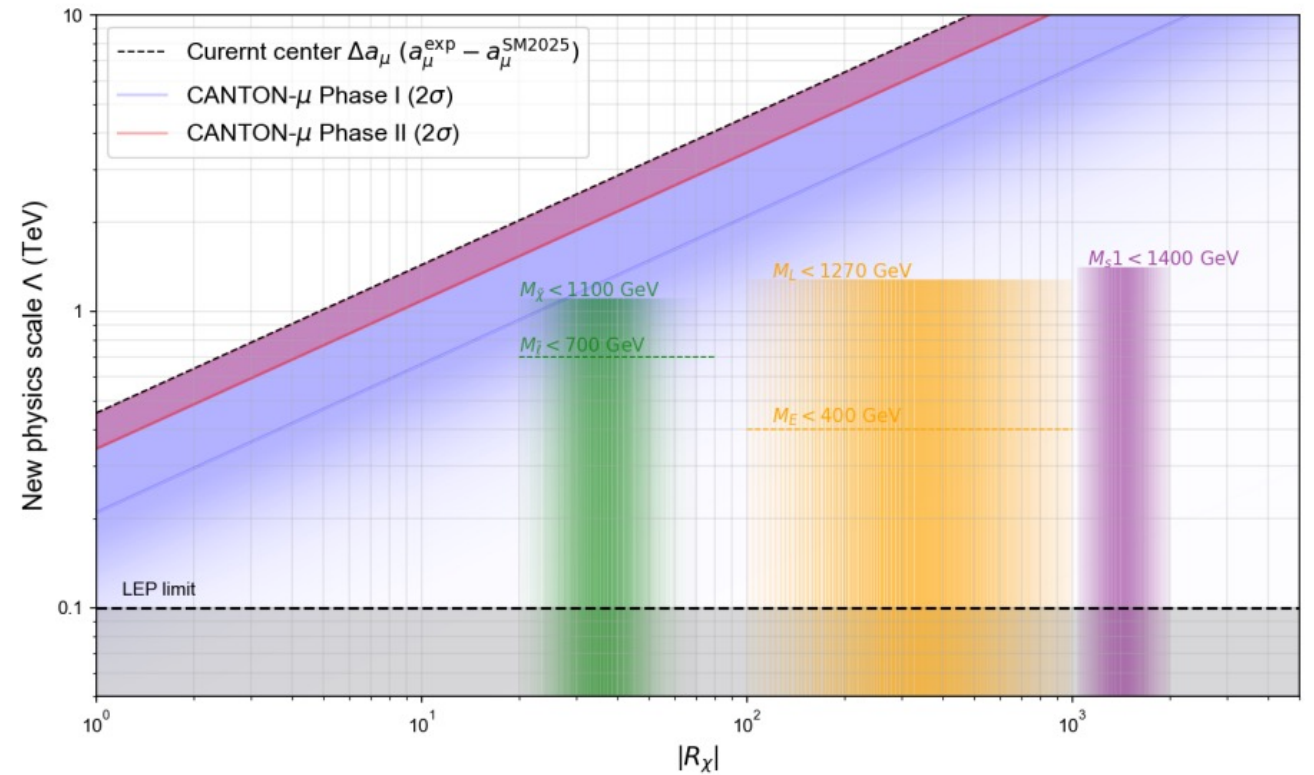

What can we probe given a 0.05 ppm?

2) Unique CPT sensitivity

- SME Lagrangian:

$$\mathcal{L}' = -a_\kappa \bar{\psi} \gamma^\kappa \psi - b_\kappa \bar{\psi} \gamma_5 \gamma^\kappa \psi - \frac{1}{2} H_{\kappa\lambda} \bar{\psi} \sigma^{\kappa\lambda} \psi + \frac{1}{2} i c_{\kappa\lambda} \bar{\psi} \gamma^\kappa \overleftrightarrow{D}^\lambda \psi + \frac{1}{2} i d_{\kappa\lambda} \bar{\psi} \gamma_5 \gamma^\kappa \overleftrightarrow{D}^\lambda \psi$$

- All terms violate Lorentz invariance
- a_κ, b_κ are CPT-odd; others are CPT-even
- Predicts two CPT/Lorentz Violating signatures for muon $g-2$:
 - [Gomes, Kostelecky, Vargas, Phys.Rev.D90:076009,2014](#)
 - **Sidereal (or annual) variation in ω_a**
 - **Difference in ω_a between μ^+ / μ^-**
 - Use frame where Z is the orientation of the earth's axis relative to the fixed, distant stars, and χ is the colatitude (earth's precession negligible in our case)

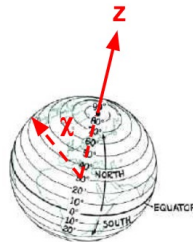

Table D21. Muon sector, $d = 3$

Combination	Result	System	Ref.
$ \text{Re } H_{011}^{\text{NR}(0B)} , \text{Im } H_{011}^{\text{NR}(0B)} , \text{Re } g_{011}^{\text{NR}(0B)} , \text{Im } g_{011}^{\text{NR}(0B)} $	$< 2 \times 10^{-22}$ GeV	Muonium spectroscopy	[20]*
$ \text{Re } H_{011}^{\text{NR}(1B)} , \text{Im } H_{011}^{\text{NR}(1B)} , \text{Re } g_{011}^{\text{NR}(1B)} , \text{Im } g_{011}^{\text{NR}(1B)} $	$< 7 \times 10^{-23}$ GeV	"	[20]*
b^T / m_μ	$(7.3 \pm 5.0) \times 10^{-7}$	Muon decay	[184]*
b_Z	$-(1.0 \pm 1.1) \times 10^{-23}$ GeV	BNL $g_\mu - 2$	[185]
$\sqrt{(\tilde{b}_X^+)^2 + (\tilde{b}_Y^+)^2}$	$< 1.4 \times 10^{-24}$ GeV	"	[185]
$\sqrt{(\tilde{b}_X^-)^2 + (\tilde{b}_Y^-)^2}$	$< 2.6 \times 10^{-24}$ GeV	"	[185]
$\sqrt{(\tilde{b}_X)^2 + (\tilde{b}_Y)^2}$	$< 2 \times 10^{-23}$ GeV	Muonium spectroscopy	[186]
$b_Z - 1.19(m_\mu d_{Z0} + H_{XY})$	$(-1.4 \pm 1.0) \times 10^{-22}$ GeV	BNL, CERN $g_\mu - 2$ data	[187]
b_Z	$(-2.3 \pm 1.4) \times 10^{-22}$ GeV	CERN $g_\mu - 2$ data	[187], [188]*
$ \text{Re } H_{011}^{(3)(0B)} , \text{Im } H_{011}^{(3)(0B)} $	$< 5 \times 10^{-23}$ GeV	"	[20]*
$\tilde{H}_{011}^{(3)}$	$(-1.6 \pm 1.7) \times 10^{-22}$ GeV	BNL, CERN $g_\mu - 2$ data	[20]*
$ \text{Re } \tilde{H}_{011}^{(3)} , \text{Im } \tilde{H}_{011}^{(3)} $	$< 2.0 \times 10^{-24}$ GeV	BNL $g_\mu - 2$	[20]*
$m_\mu d_{Z0} + H_{XY}$	$(1.8 \pm 6.0) \times 10^{-23}$ GeV	"	[185]

Slides courtesy: Breese Quinn, On Kim

What can we probe given a 0.05 ppm?

2) Unique CPT sensitivity

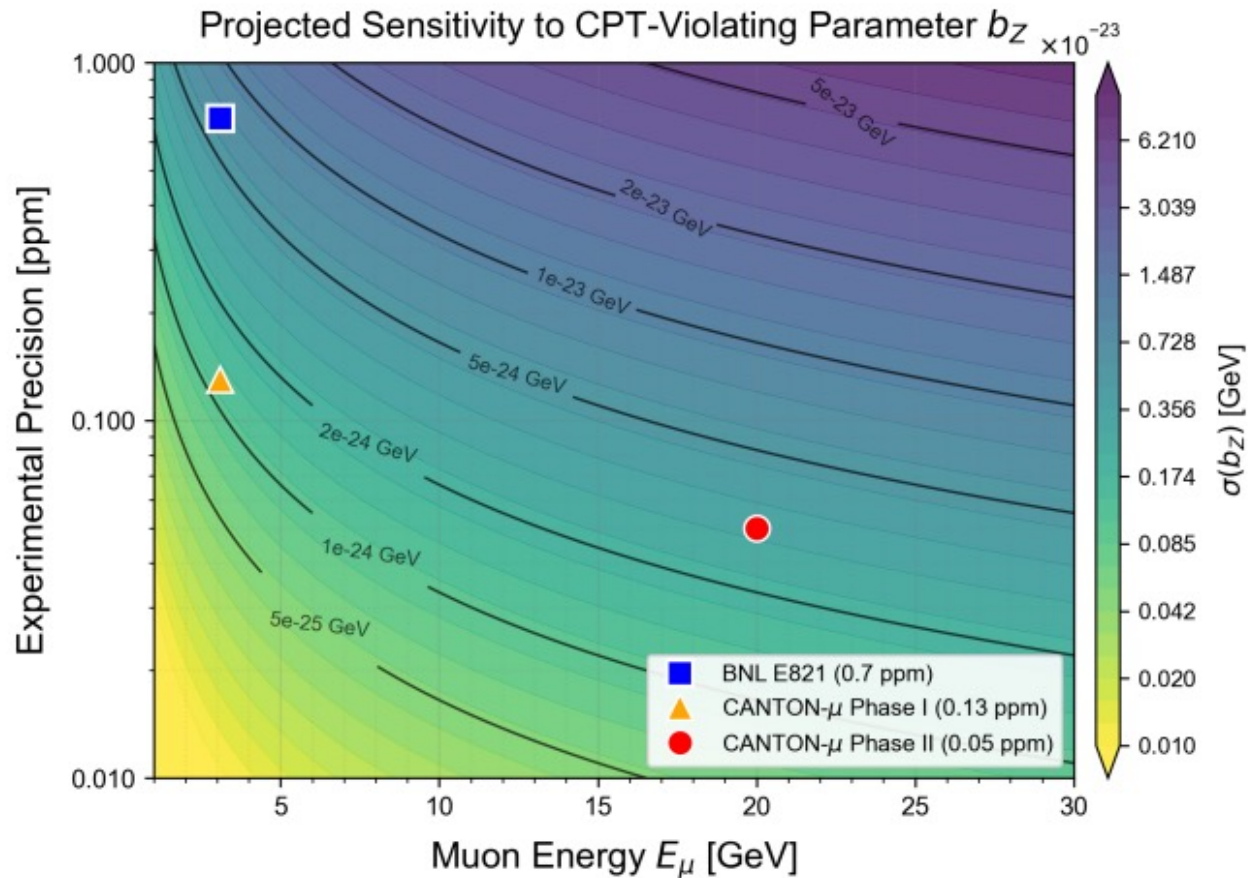

Facility	Latitude ϕ	Colatitude $\chi = 90^\circ - \phi$
BNL	40.9°N	49.1°
Fermilab	41.9°N	48.1°
CERN	46.2°N	43.8°
J-PARC	36.5°N	53.5°
HIAF	23.1°N	66.9°

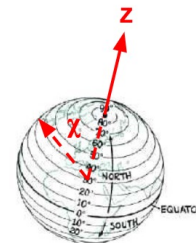

Final remarks

- Generations of muon $g-2$ experiments over the past 50 years have been at center stage in SM evolution.
- The 'magic- γ ' approach through CERN/BNL/Fermilab has reached the endgame. **New approach is needed to take over.**
- In the coming decades, the theory puzzles likely to be resolved, with the precision matching the Fermilab level - calling for new experimental input.
- New experiments will take decades - the time to start is **now**.
- Grazie!

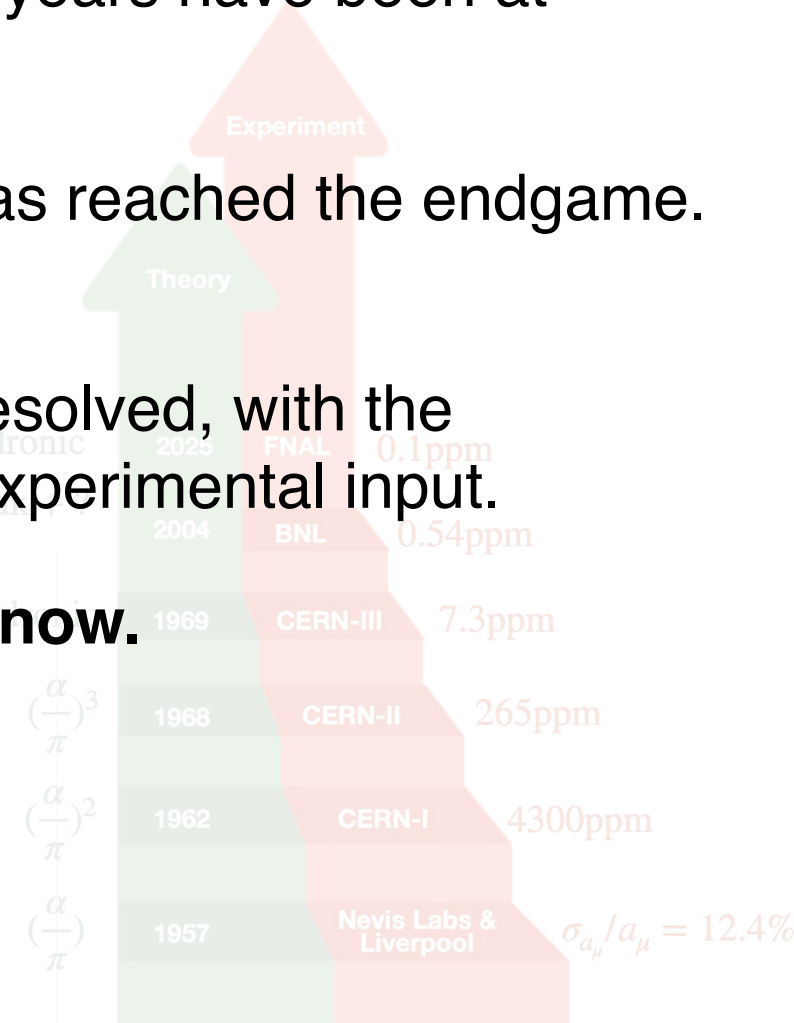

backup

What can we probe given a 0.05 ppm?

Significance

New physics significance depends on the central values from both theory and experiment

$$\Delta a_{\mu}^{\text{Exp-WP2020}} = 26.2(4.5) \times 10^{-10},$$

$$\Delta a_{\mu}^{\text{Exp-WP2025}} = 3.8(6.3) \times 10^{-10}$$

- Phase-1 can reach 5σ for the exp central value centered on BNL (μ^-) vs. SM2025
- Phase-2 can reach $\sim 3\sigma$ for FNAL vs. SM2025 (assuming 0.1 ppm for theory)

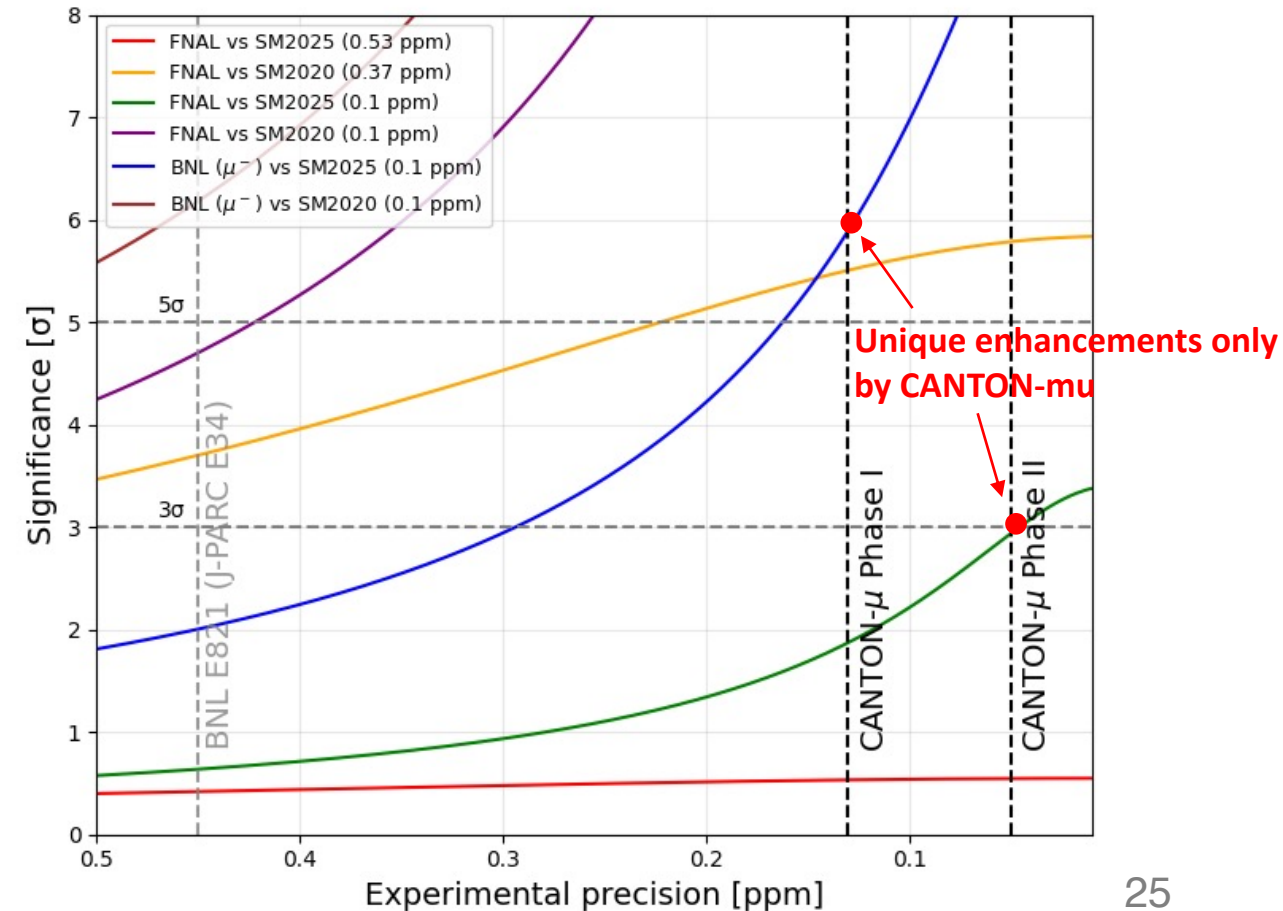

What can we probe given a 0.05 ppm?

New-Physics energy scale

- An independent precise experimental result would decisively clarify the current WP20 vs WP25 puzzles over many NP models

P. Athron et al., Prog.Part.Nucl.Phys. 148 (2026) 104225

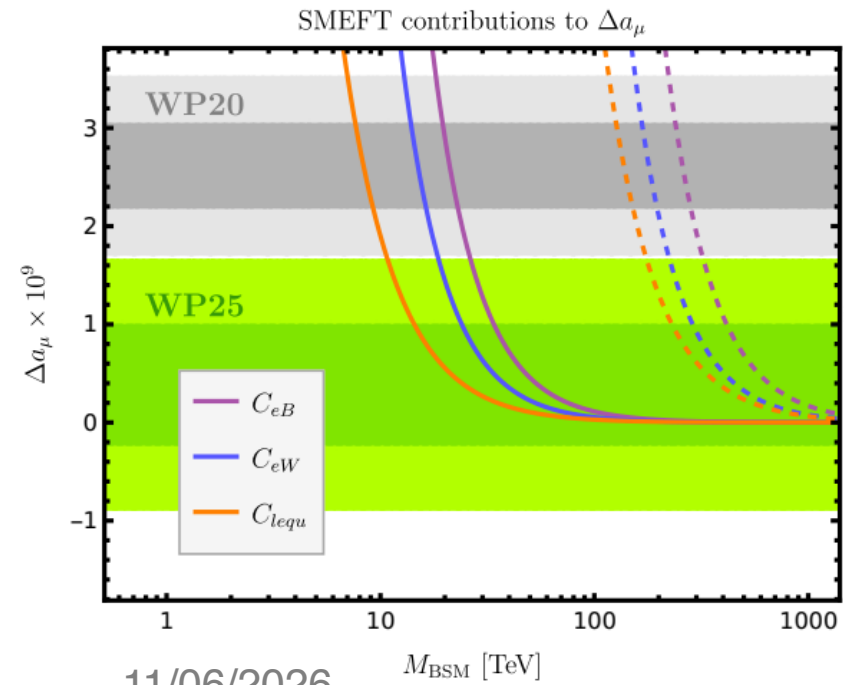

11/06/2026
SMEFT Wilson coefficients

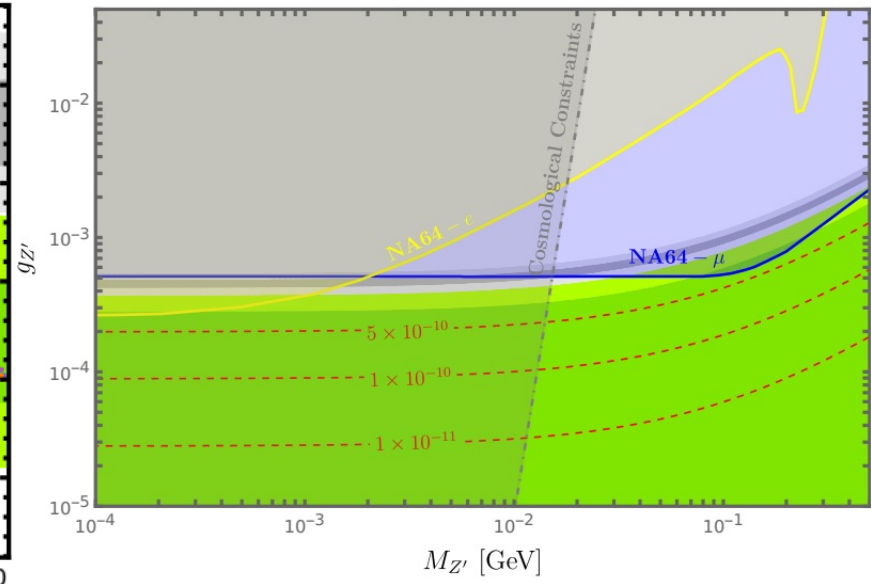

Z prime constraint

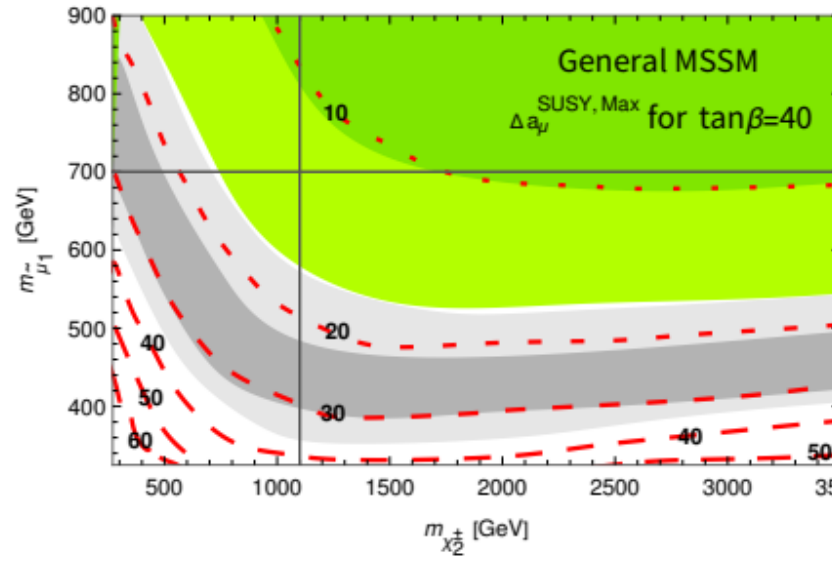

SUSY MSSM contribution

Physics and technical synergies

- Polarized protons: synergy with the Electron-ion collider project (EIC or EicC)
- Neutrino factory (NvStorm)
- Muon collider?

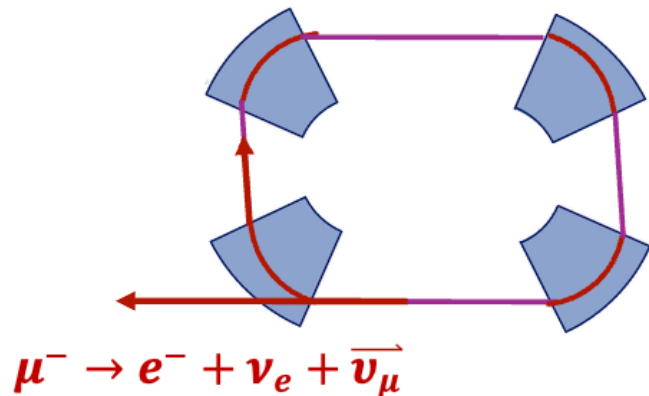

ν from *STORed* Muons (*nuSTORM*)

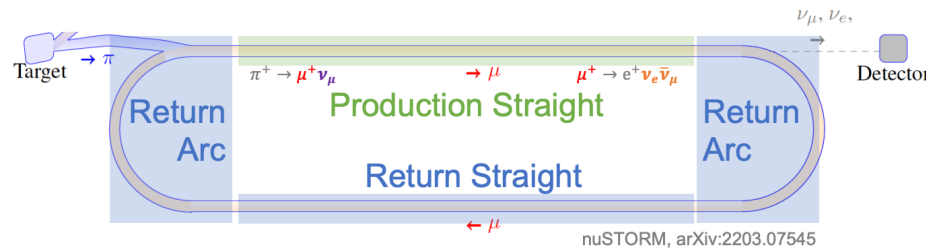

courtesy: Xianguo LU

➤ nuPIL: an improved version of nuSTORM production straight, a standalone beam line for DUNE

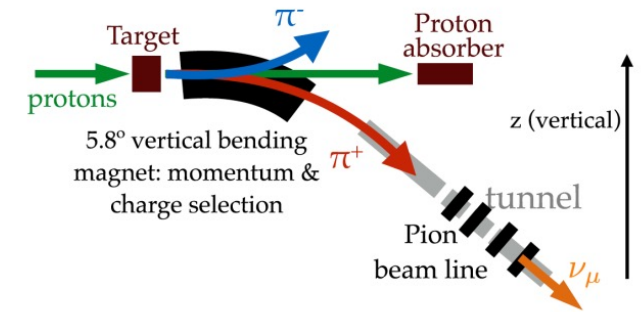

FIG. 1: Scheme of the nuPIL concept.

Lessons learned 2) systematics improvement



Replace calorimeters with in-vacuo silicon trackers

- Removes/reduces **gain** & **pile-up** issues
- Azimuthal coverage reduces beam systematics

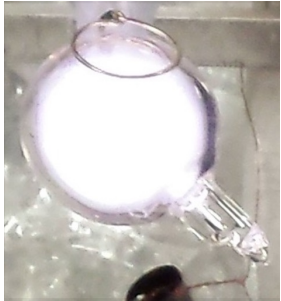

Improve field extraction

- Better calibration chain, mapping & use of ^3He
- $\delta(m_\mu/m_e)$ of 22 ppb will decrease with MuSEUM experiment

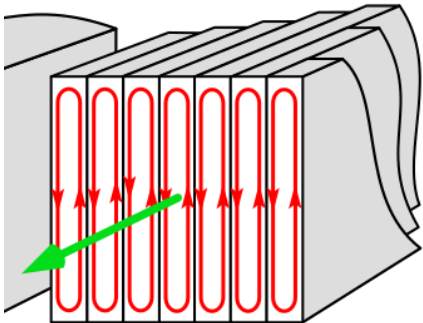

Design out transient fields

- Remove pulsed electrostatic quadrupoles
- Redesign vacuum chambers to control kicker eddy currents

<https://arxiv.org/abs/2512.16980>

The anomalous magnetic moment of the muon: status and perspectives

David W. Hertzog¹ and Martin Hoferichter²

¹University of Washington, Department of Physics, Box 351560, Seattle, WA 98195, USA

²Albert Einstein Center for Fundamental Physics, Institute for Theoretical Physics, University of Bern, Sidlerstrasse 5, 3012 Bern, Switzerland

5.2. Can an experiment go beyond 124 ppb?

5.2.2. At FNAL. Inevitably, the question arises: *Can one do better at FNAL?* Despite the present limitations of the SM prediction, we describe a thought exercise that illustrates a potential path toward an improved experimental precision by roughly a factor of three—to the level of $\simeq 40$ ppb—should future developments warrant it.¹¹ The concept envisions a ten-fold increase in statistics (30 ppb) combined with a three-fold reduction in systematics (25 ppb). The external constant uncertainties should decrease to about 10 ppb because of anticipated future muonium experiments (200).

In this discussion, the existing FNAL SR, beamlines, and supporting infrastructure are largely retained. The PIP-II LINAC upgrade (201) is expected to deliver a 30% higher proton flux at a 33% faster repetition cycle. It will be necessary to upgrade the Recycler RF system to better rebunch the injected proton batches into shorter pulses. This will both improve the kicker efficiency and largely eliminate the systematic uncertainty from differential decay (see Fig. 2(C)). Current $g - 2$ simulations indicate that 25 ns-long bunches are stored 1.7 times more efficiently and another multiplicative factor of 1.3 can be realized by installing the built, but never used, open-ended inflector. Additional nearly two-fold storage efficiency is expected if the ESQ voltages can be raised to their design values, a challenge that remains owing to sparks that limited the maximum voltage in F089. These

arXiv:2512.16980v2 [hep-ph] 18 Feb 2026

Ann. Rev. Nucl. Part. Sci. 2026. 76:1–27

<https://doi.org/10.1146/annurev-nucl-102422-040841>

Copyright © 2026 by the author(s).
All rights reserved

Keywords

anomalous magnetic moment, muon

Abstract

We review the status of the anomalous magnetic moment of the muon as a precision probe of physics beyond the Standard Model (SM) after the release of the final results from the Fermi National Accelerator Laboratory (FNAL) Muon $g - 2$ experiment and the second White Paper of the Muon $g - 2$ Theory Initiative. While the SM prediction requires further improvements by a factor of four to fully leverage the sensitivity achieved in experiment, the FNAL measurement will set the standard for many years to come, and we discuss a variety of features of the experimental campaign that made this achievement possible. In going forward, we discuss current efforts to improve the SM prediction, and imagine how an experiment would have to be devised to surpass 124 ppb in precision.

The Full Recipe - a real-world equation

Corrections from Beam Dynamics

$$a_{\mu} = \frac{\omega_a}{\omega_p} \times \frac{(1 + C_e + C_p + C_{pa} + C_{dd} + C_{ml})}{(1 + B_k + B_q)} \times \left[\frac{\mu'_p(T_r)}{\mu_e(H)} \frac{\mu_e(H)}{\mu_e} \frac{m_{\mu}}{m_e} \frac{g_e}{2} \right]$$

Corrections from Magnetic Field Transient

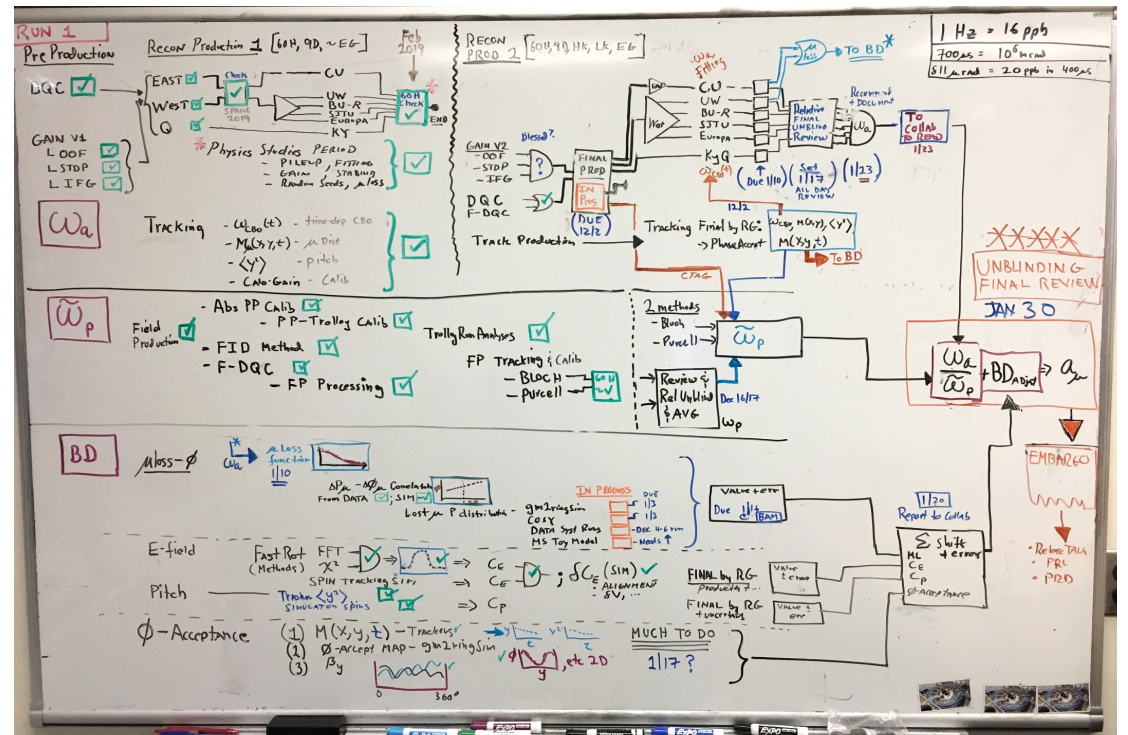

Statistics: After 6 years of running

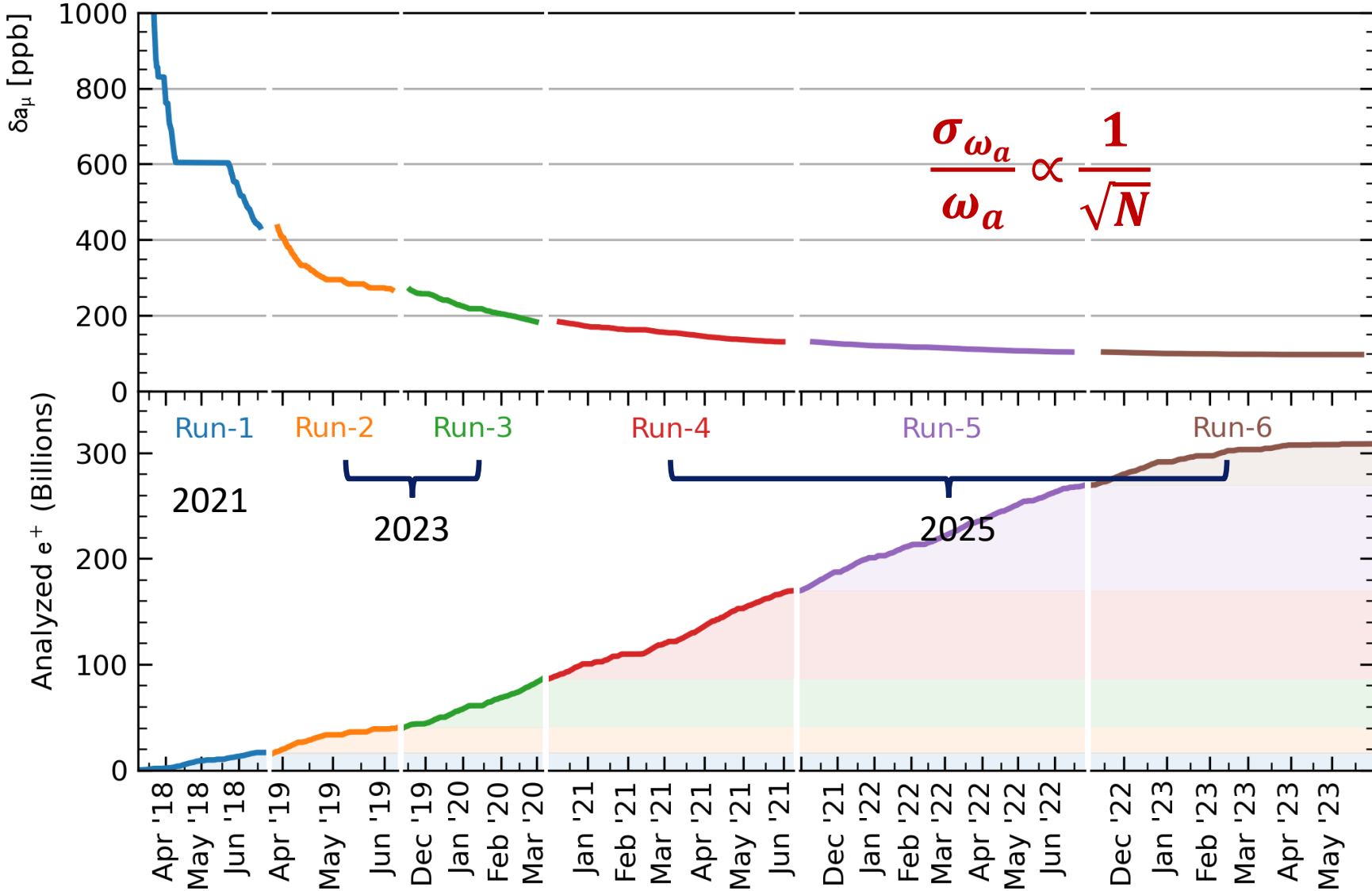

Final uncertainty budget

$$\frac{f_{clock} \omega_a^{meas} (1 + C_e + C_p + C_{ml} + C_{pa} + C_{dd})}{f_{calib} \langle \vec{x}(x, y, \phi) \times \omega_p(x, y, \phi) \rangle (1 + B_k + B_q)}$$

Run-4/5/6

Quantity	Correction (ppb)	Uncertainty (ppb)
ω_a^m (statistical)	...	114
ω_a^m (systematic)	...	30
C_e Electric Field	347	27
C_p Pitch	175	9
C_{pa} Phase Acceptance	-33	15
C_{dd} Differential Decay	26	27
C_{ml} Muon Loss	0	2
$\langle \omega_p' \times M \rangle$ (mapping, tracking)	...	34
$\langle \omega_p' \times M \rangle$ (calibration)	...	34
B_k Transient Kicker	-37	22
B_q Transient ESQ	-21	20
μ_p' / μ_B	...	4
m_μ / m_e	...	22
Total systematic for \mathcal{R}'_μ	...	76
Total for a_μ	572	139

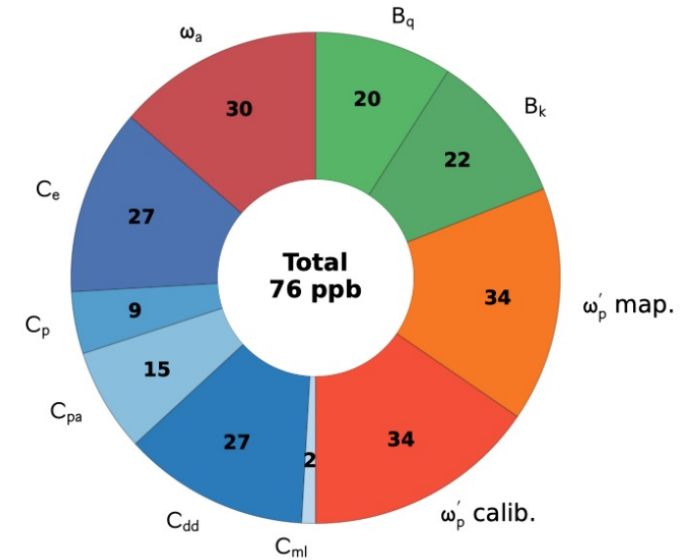

- TDR goal: 100 ppb ✓
- Systematics are “evenly” distributed:
 - No dominant source
 - Further improving would require to reduce in many categories **together!**
 - **How?**