

*The MUonE Experiment : a third
path to understanding the muon*
g-2

Giorgia Cacciola
on behalf of the MUonE collaboration



UNIVERSITY OF
LIVERPOOL

LEVERHULME
TRUST

Outline

- Muon $g-2$
- Status of MUonE
- Results from 2025 Data

Muon $g-2$

- Tension between data-driven and lattice determinations of SM prediction of a_μ
- a_μ is calculated by : $a_\mu^{SM} = a_\mu^{QED} + a_\mu^{EW} + a_\mu^{HAD}$
- $a_\mu^{HAD,LO}$ is the largest source of uncertainty on the theoretical determination as it cannot be calculated using perturbation theory
- Different methods of using e^+e^- are in disagreement with each other
- Lattice in agreement with data but in disagreement with e^+e^- .
- Muon $g-2$ – there is still work to do !

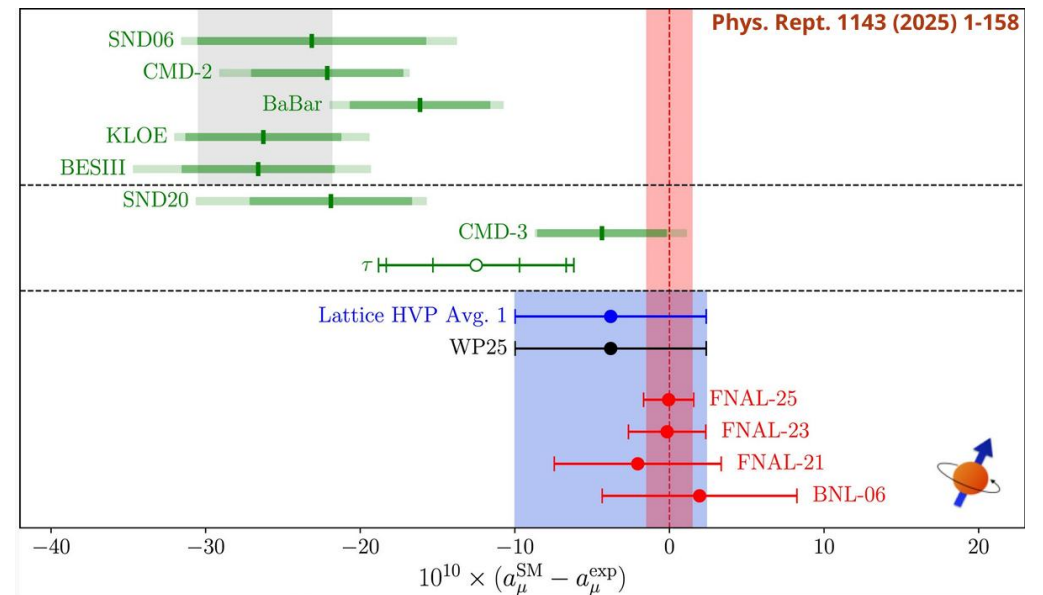
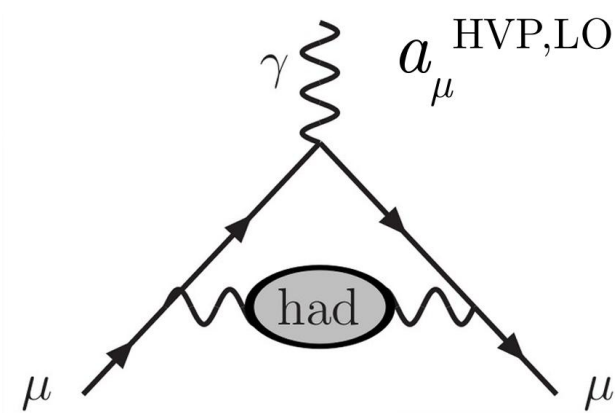

Motivation of MUonE

- The aim of MUonE is to have an independent measurement of a_μ^{HLO} using :

$$a_\mu^{HLO} = \frac{\alpha}{\pi} \int_0^1 dx (1-x) \Delta\alpha_{had}[t(x)]$$

$$t(x) = \frac{x^2 m_\mu^2}{x-1} < 0$$

We measure

- This integral is in the space-like region with negative momentum transfer, $t(x)$
- Advantage of this integral : smooth function

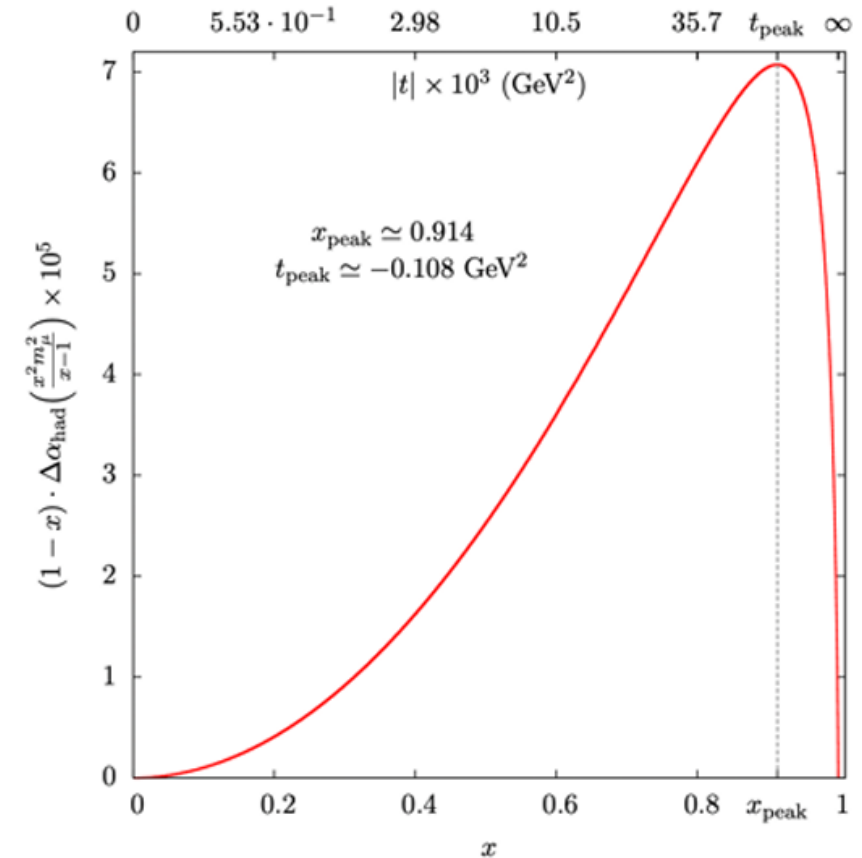

Physics Letters B
746 (2015) 325-329

μ - e Elastic Scattering

$\Delta\alpha_{had}(t)$ can be extracted from the shape of the elastic scattering differential cross-section

Advantage of the μ - e elastic process is the simple kinematics.

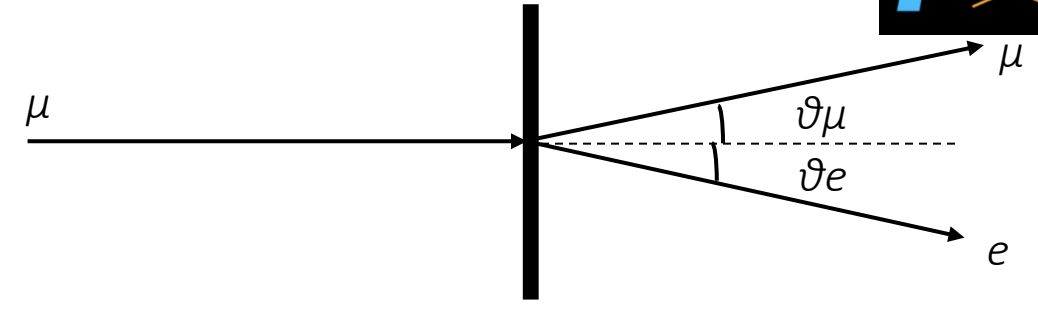

We can use the correlation to reject background events as **elastic events are planar**, and the background events are not
 $\mu N \rightarrow \mu N e+e-$
 (main background)

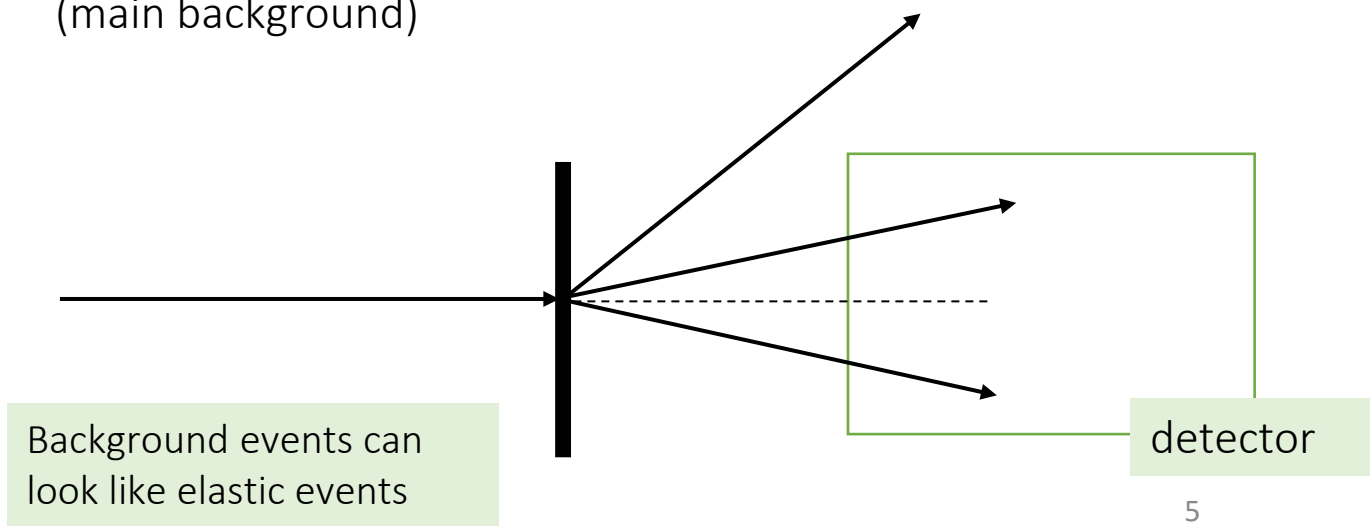
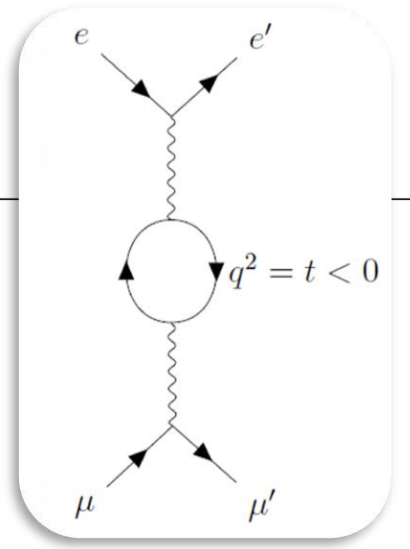
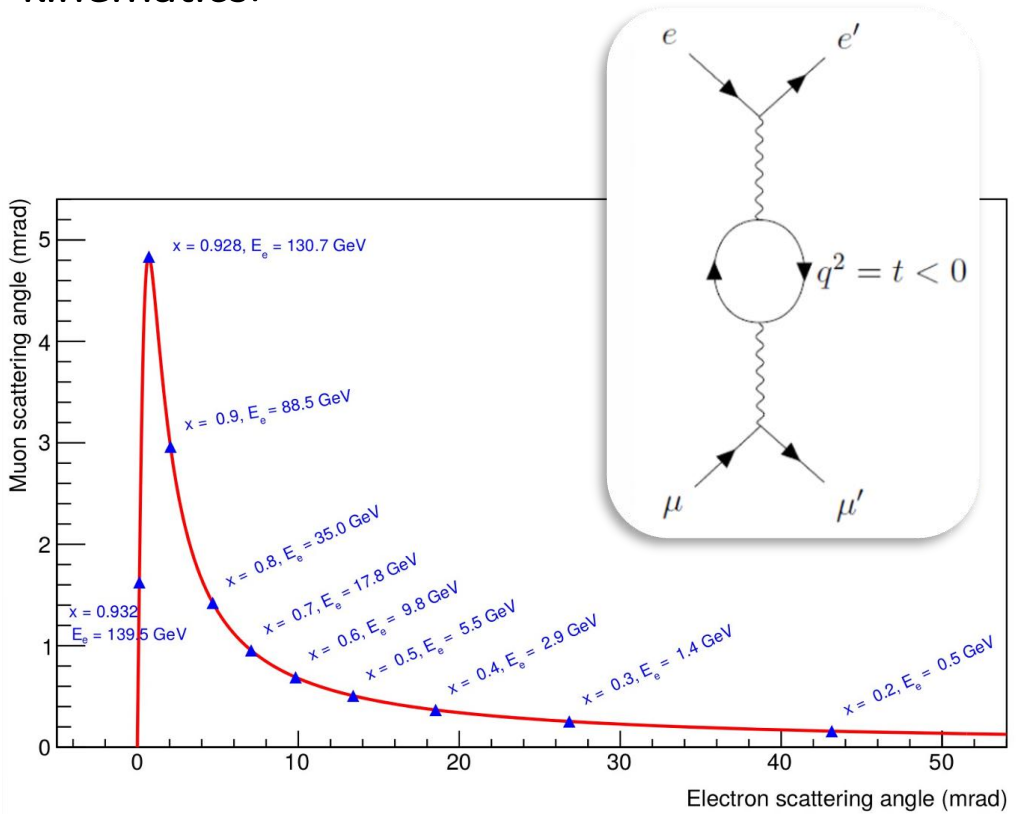

Extraction of $\Delta\alpha_{had}(t)$

➤ The extraction of $\Delta\alpha_{had}(t)$ -> template fit on the distribution of the two scattering angles

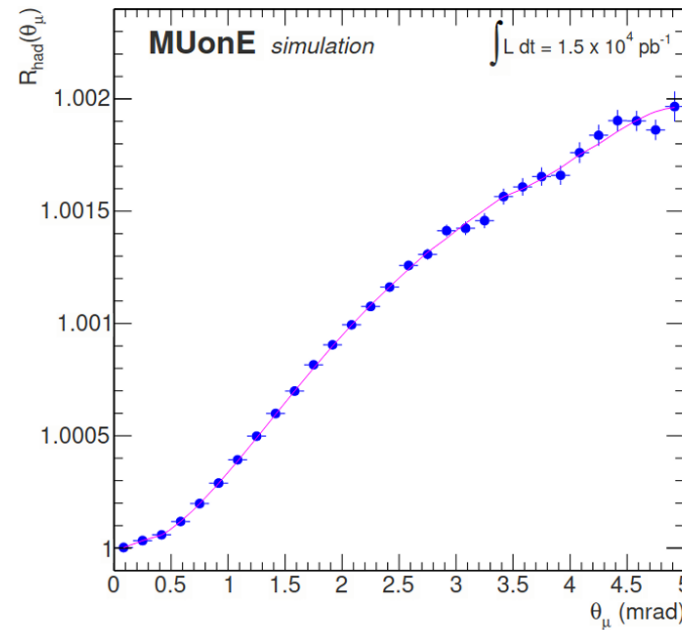
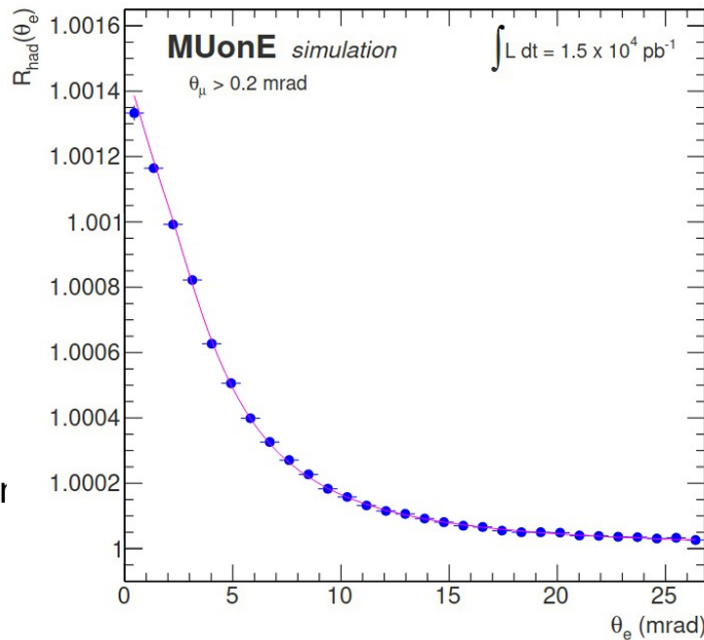

data

$$R_{had}(\theta) = \frac{d\sigma(\theta, \Delta\alpha_{had})}{d\sigma(\theta, \Delta\alpha_{had}=0)} \sim 1 + 2\Delta\alpha_{had}$$

MC

➤ Sensitive to $\Delta\alpha_{had}(t)$ with large muon angles and small electron angles

Experimental Setup

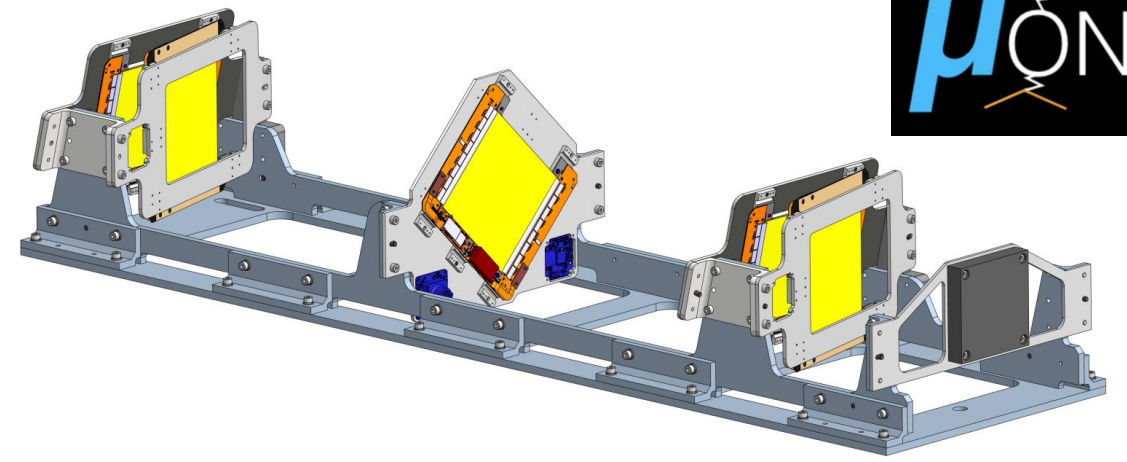

At M2 Beamline in CERN north area

Each station has its own **low -Z target** of around **2 cm** thickness and tracking system.

One station is made up of silicon strip sensors

40 tracking stations

Modular structure to decrease effects of multiple scattering

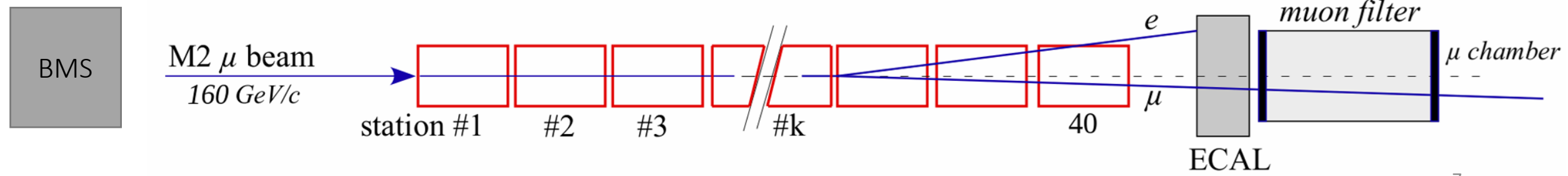

Precision of MUonE

- The challenge of MUonE is on the precision of the experiment.
- The goal is to have a statistical uncertainty of 0.3% and a similar systematic uncertainty.
- Cross section to be known at 10ppm in the signal region
- Such precision is predicted to take 3 years of data taking with 40 stations.
- To take place after CERN Long Shutdown 3 (2027-2029)

Main systematics effect :

1. Intrinsic angular resolution, 1 μm
2. Multiple scattering; 1%
3. Beam energy knowledge (few MeV)- longitudinal alignment.
4. Longitudinal alignment in $z < 10 \mu\text{m}$
5. The ratio of NNLO/LO should be $1e^{-4} - 1e^{-3}$

Example: $\pm 10\%$ systematic error on the angular intrinsic resolution

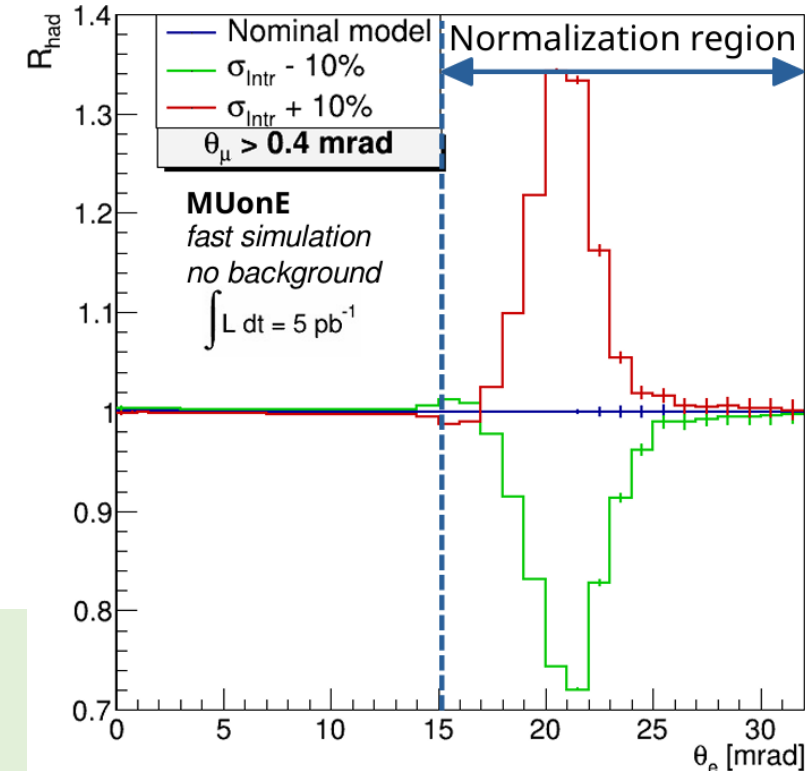

$$R_{had}(\theta) = \frac{d\sigma(\theta, \Delta\alpha_{had})}{d\sigma(\theta, \Delta\alpha_{had}=0)}$$



2025 Test Run

- BMS
- 3 Tracking stations
- ECAL
- Muon filter station
- Timing detectors

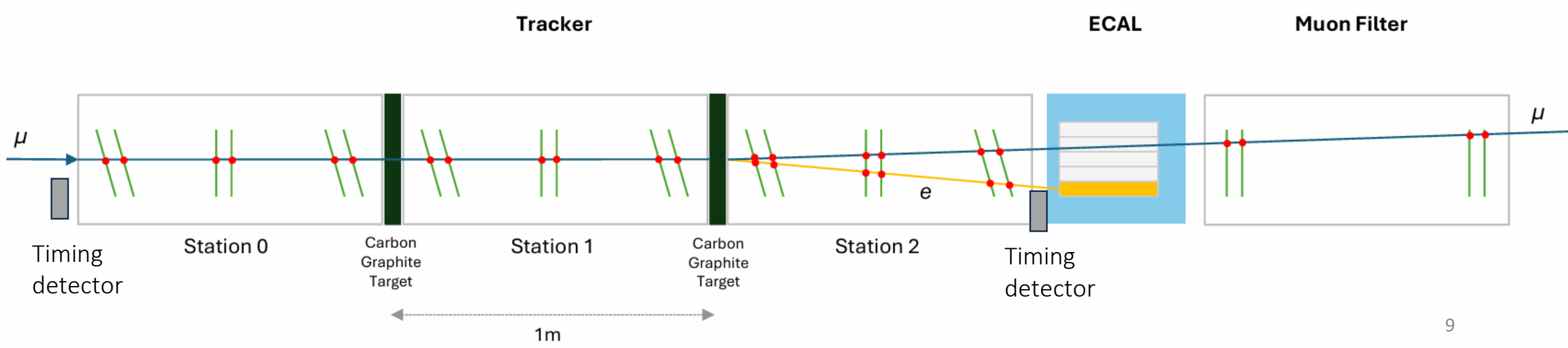
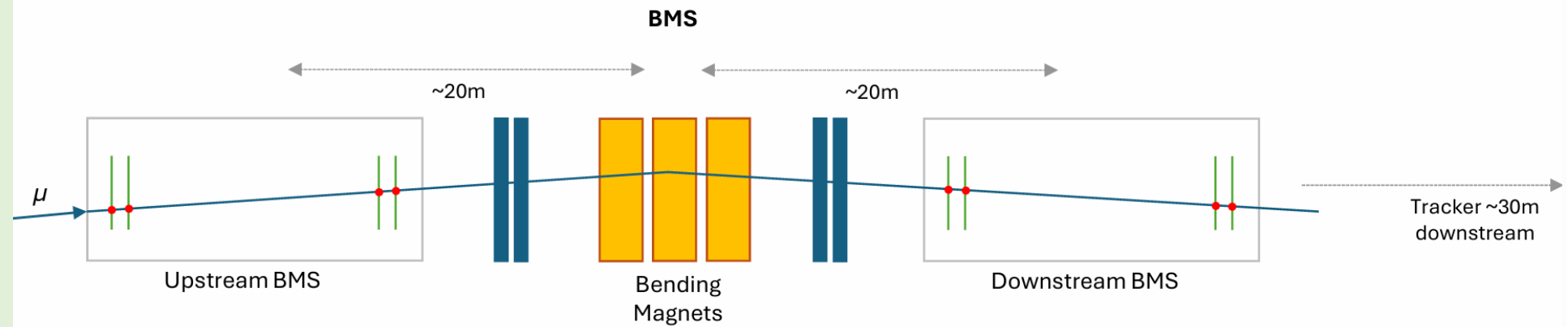

M2 beamline

- MUonE location: upstream of the AMBER detector
- 160 GeV muons
- Spill duration 4.8 s, ~ 25% duty cycle
- Muons asynchronous to the DAQ clock
The DAQ is designed to this feature
- $\sim 2 \times 10^8 \mu^+/\text{spill}$ \rightarrow 40 MHz average rate in-spill

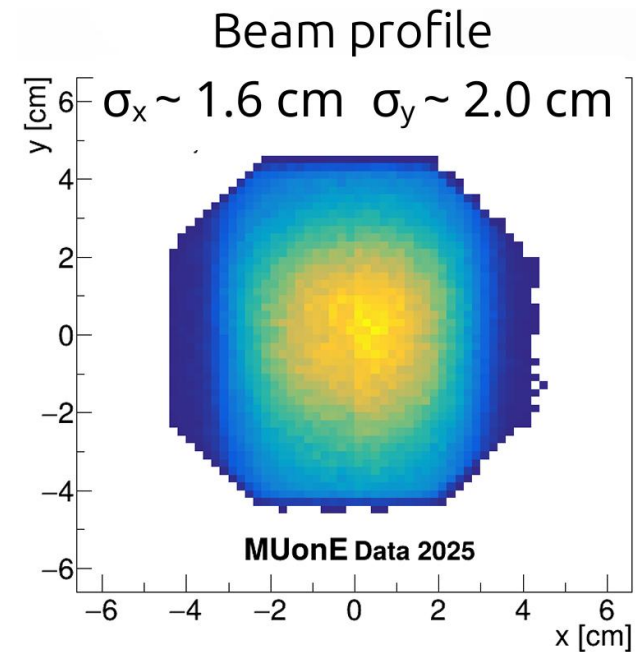

2S Modules

- 2 silicon strip sensors of 320 μm thickness that are reading the same coordinate
- The two sensors are separated by 1.8mm
- Suppresses background of single sensor hits
- Reject large angle tracks
- Pitch : 90 μm
- Readout rate : 40MHz , M2 beam has a similar intensity
- Area : $10 \times 10 \text{cm}^2$

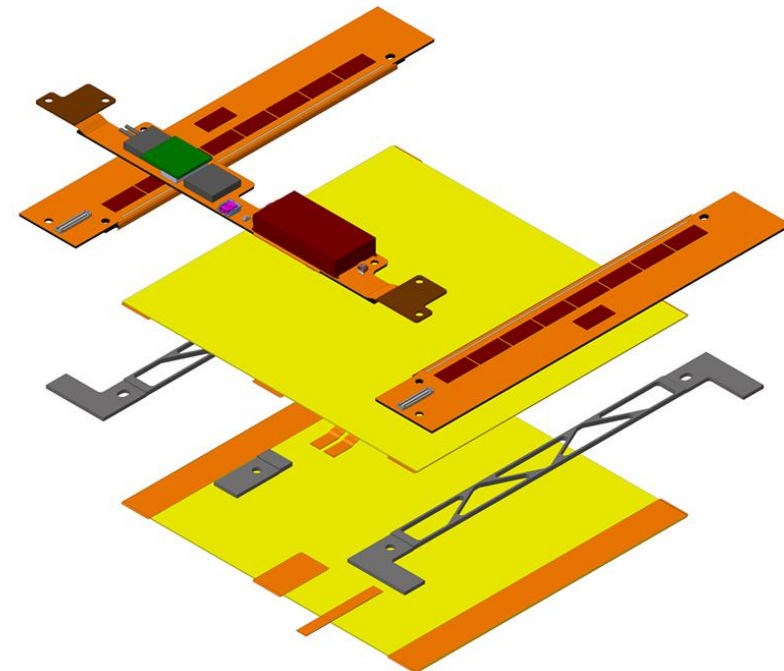
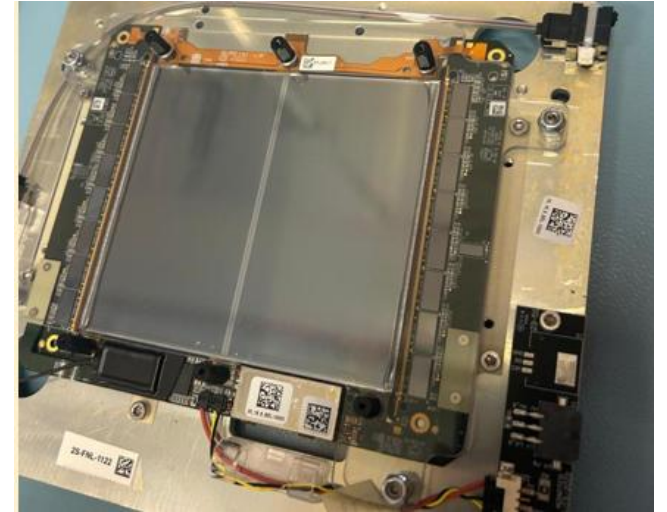

[The Phase-2 Upgrade of the CMS Tracker](#)

Tracking System

MUonE preliminary

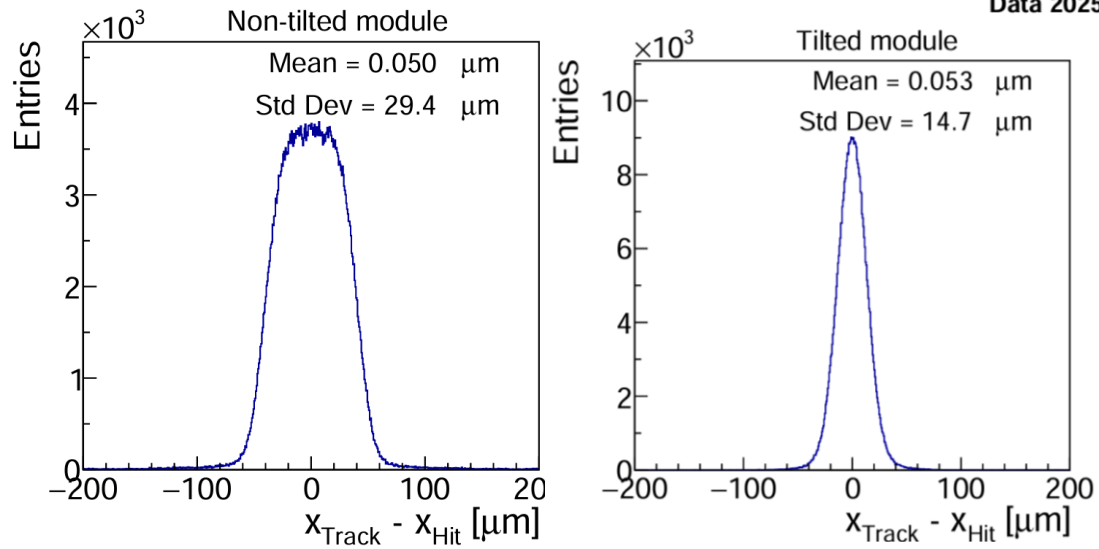

Data 2025

Hit resolution after track error subtraction:
 $\sigma_{hit}(\text{non-tilted}) \sim 22 \mu\text{m}$ $\sigma_{hit}(\text{tilted}) \sim 12 \mu\text{m}$

X and Y modules :
tilted by 233 mrad
 $\rightarrow 2\times$ hit resolution
improvement

(u, v) modules:
solve reconstruction
ambiguities

Invar support
structure

2 cm graphite
target

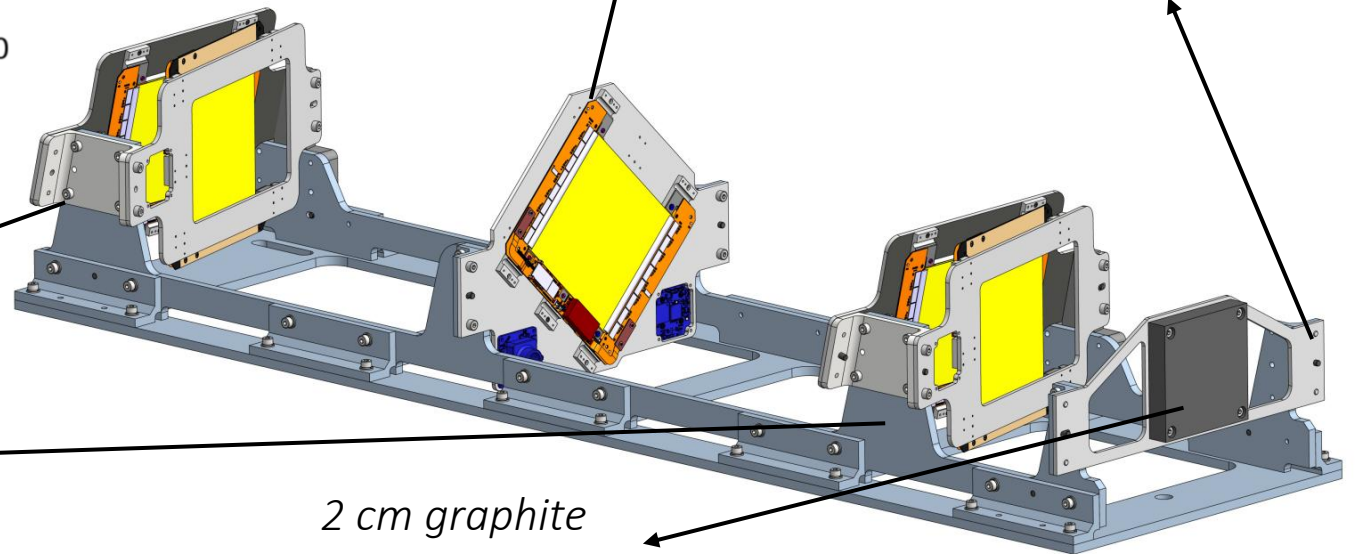

DAQ

- Beam is asynchronous to DAQ clock
- Serenity board (developed for CMS Phase2 Upgrade)

1. 36 communication links with sub-detectors
 - 30 2S modules
 - 4 ECAL
 - 2 timing detectors

Online selection based on tracker modules occupancy.

Event rate is reduced from 40 MHz (no selection) to ~500 kHz

2. Event building:

Group information from all sub-detectors in a time-coherent packet of data.

Online decoding provides analysis-ready data in real time

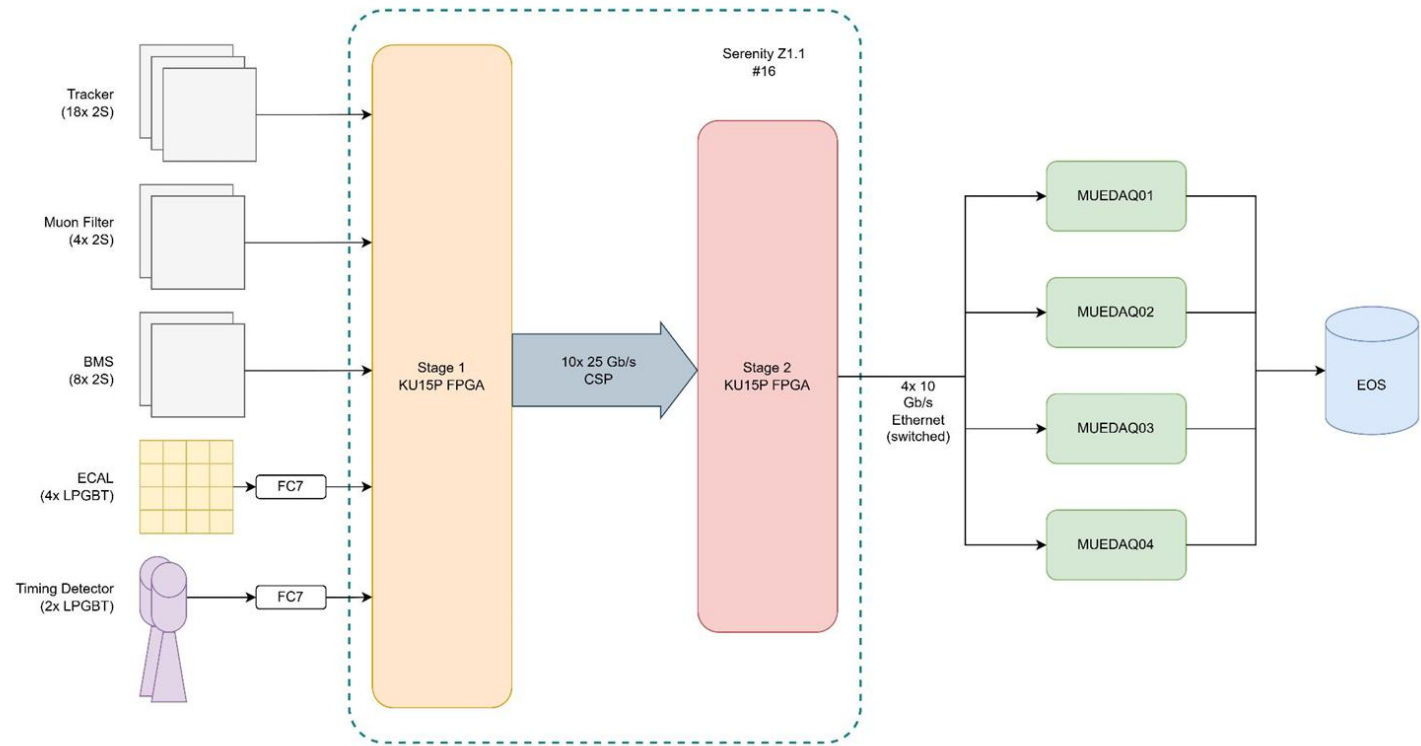

MUonE PID

ECAL

- 5x5 PbWO4 crystals (CMS ECAL)
- Area: 2.85×2.85 cm², length: 23 cm
- Total ECAL area: $\sim 14 \times 14$ cm²
- Readout: 10x10 mm² APD
- Independent measurement of electron energies (1–150 GeV)
- Compare energy against track angle to filter radiative background
- Useful for the independent measurement of $\Delta\alpha_{had}$ with electron energy



Muon Filter

- Tracks muons after the ECAL, where electrons have been absorbed
- Improves PID by connecting tracks before and after the ECAL
- Filters beam contamination
- In 2025 test : made of 4 2S modules with no tilting

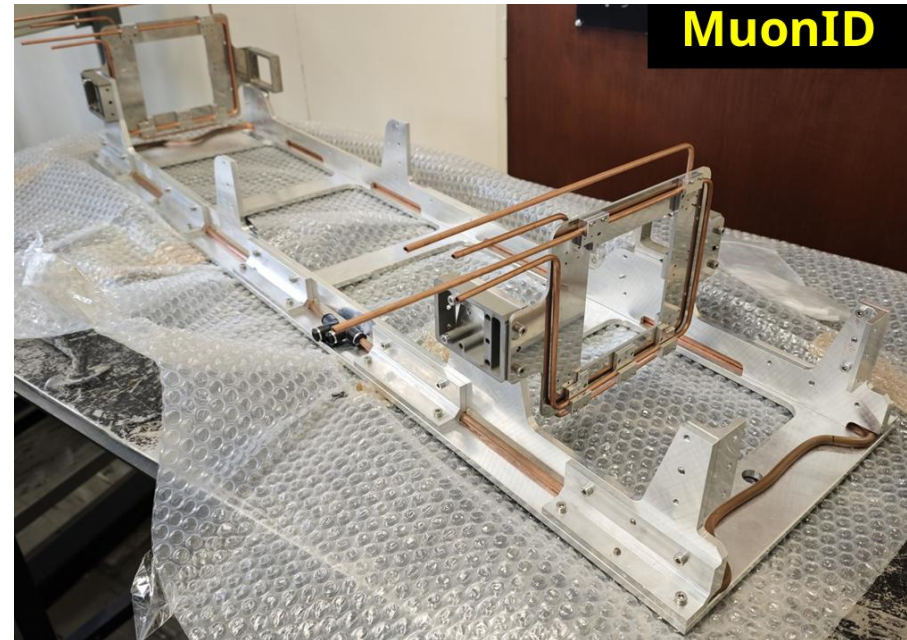

The Beam Momentum Spectrometer (BMS)

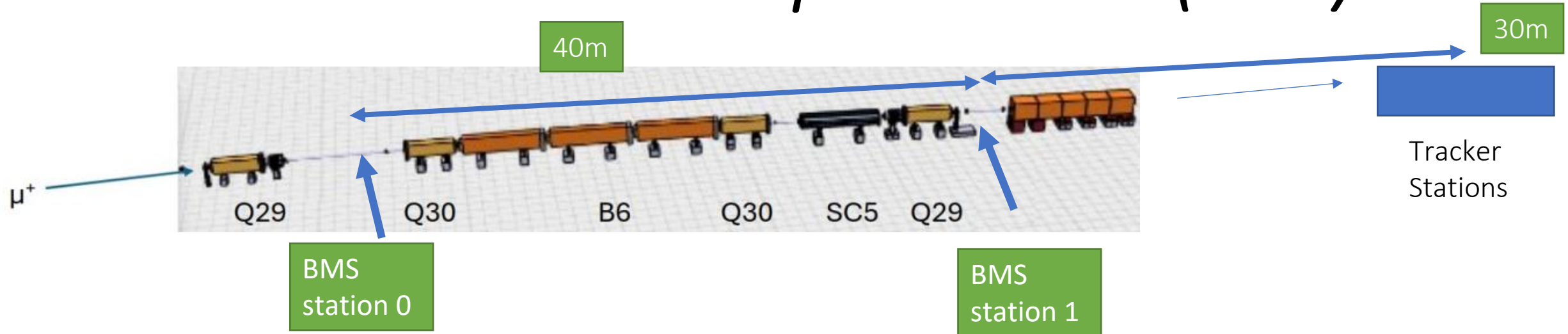

- B6 : bending magnet
~30mrad vertical deflection of the beam
Bending Power = 16 Tm
- The BMS allows us to measure the energy of individual incoming muons before they reach the tracker.
- This is important as knowledge of the beam energy is one of the main sources of systematic error on the extraction of α_{μ}^{HLO}

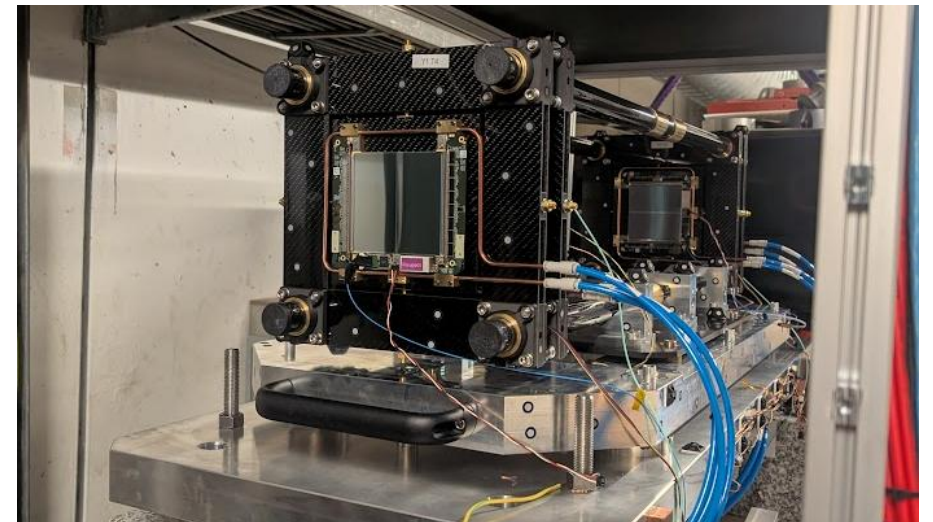

Preliminary BMS Analysis

Investigating number of particles detected in the BMS stations and compare to what we are seeing in the tracker stations

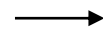

There are 3 structures visible :

- (A) 1 particle in Station 0 of the tracker and 1 particle in the BMS
- (B) 2 particles in Station 0 of the tracker and 2 particles in the BMS
- (C) there is a smaller amount of 3 particle in station 0 of the tracker and 3 particles in the BMS

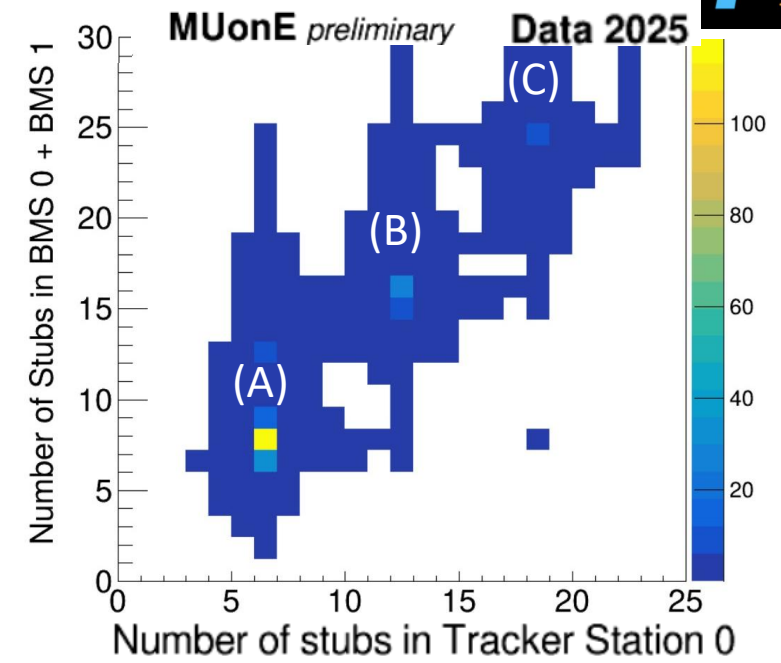

Deflection between stations is present
This is not the real deflection the beam

To give full interpretation of these results a full metrology is needed as the two slopes are calculated in two different reference systems

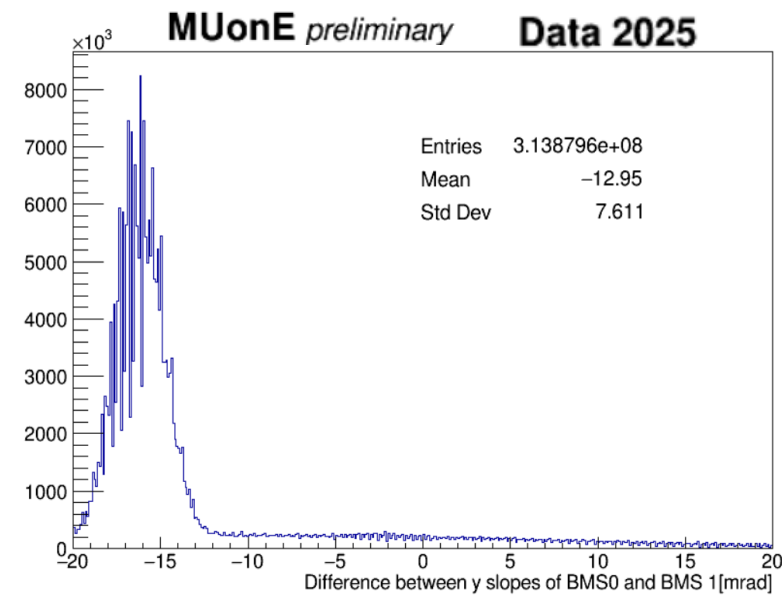
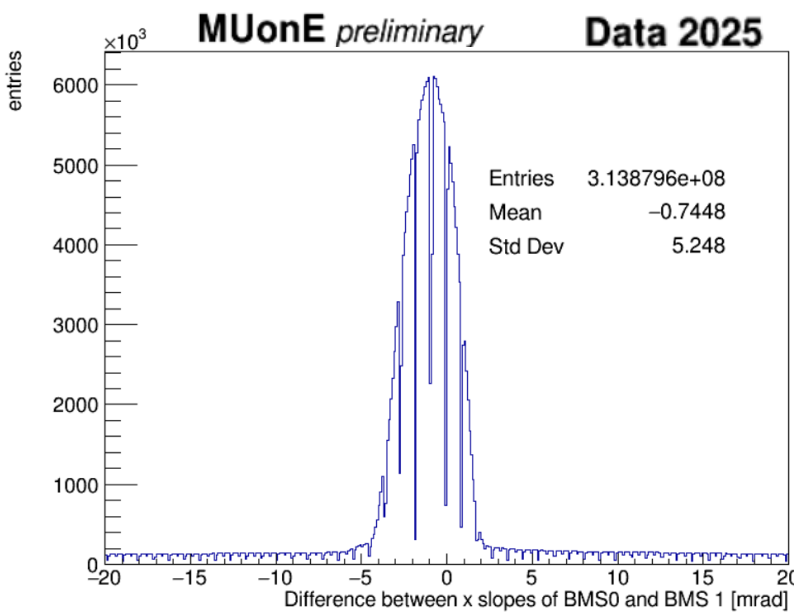

Performance of Tracker

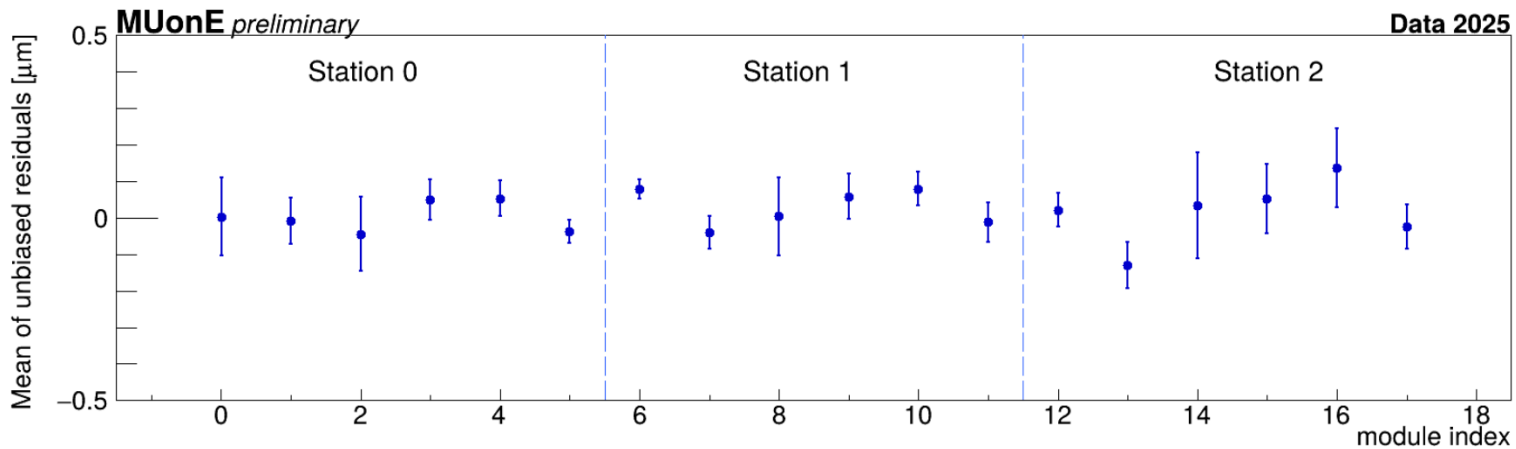

The Residuals are aligned $< 0.2 \mu\text{m}$

Efficiency \sim
98%-99%

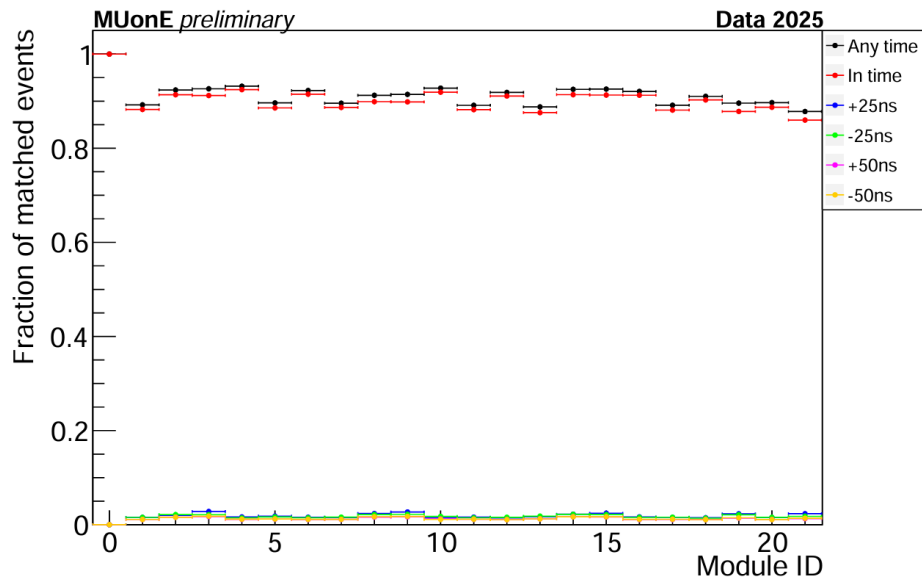
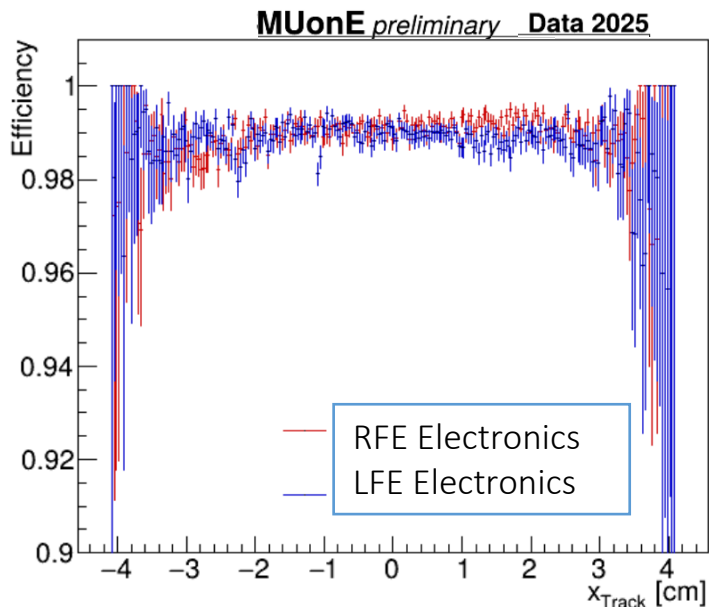

Successful fine time tuning on each module

Elastic Scattering Events in the Tracker

The events selected have :

- 1 incoming track
- 2 outgoing tracks
- No extra hits in the stations
- Reject non-planar events
- Selecting z-vertex :

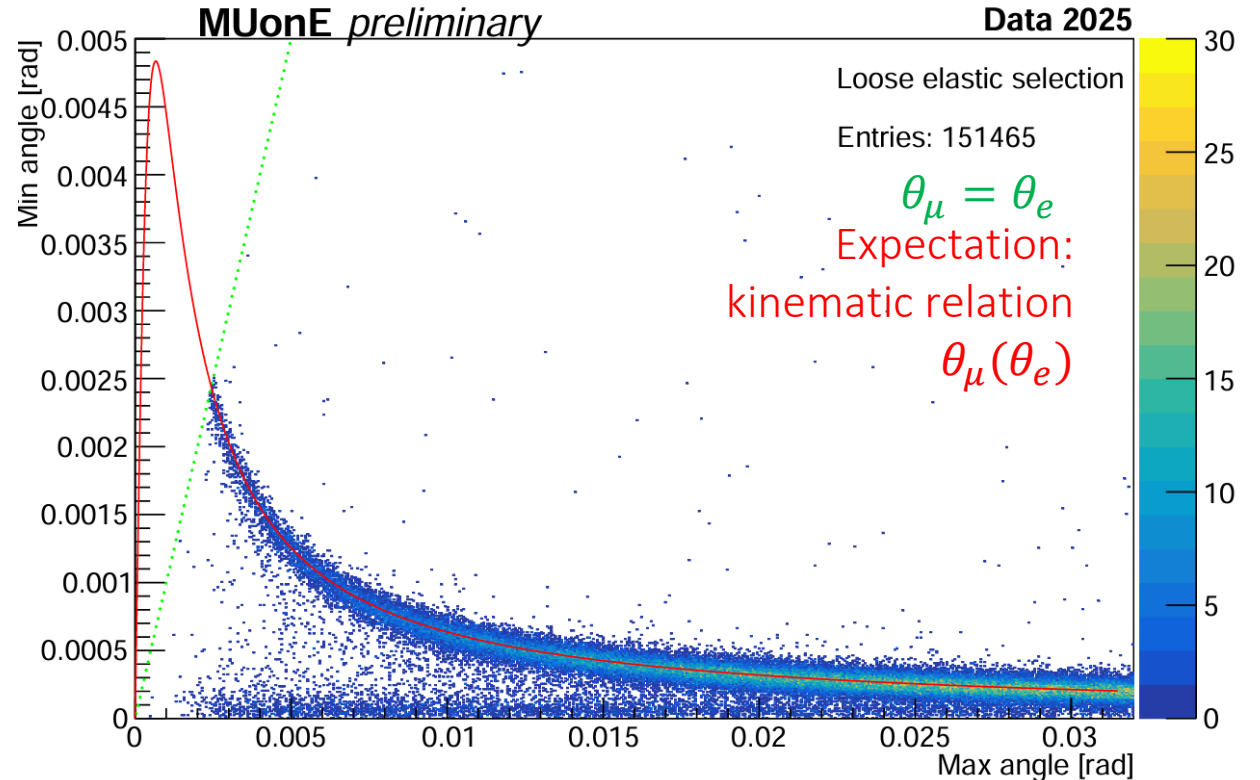
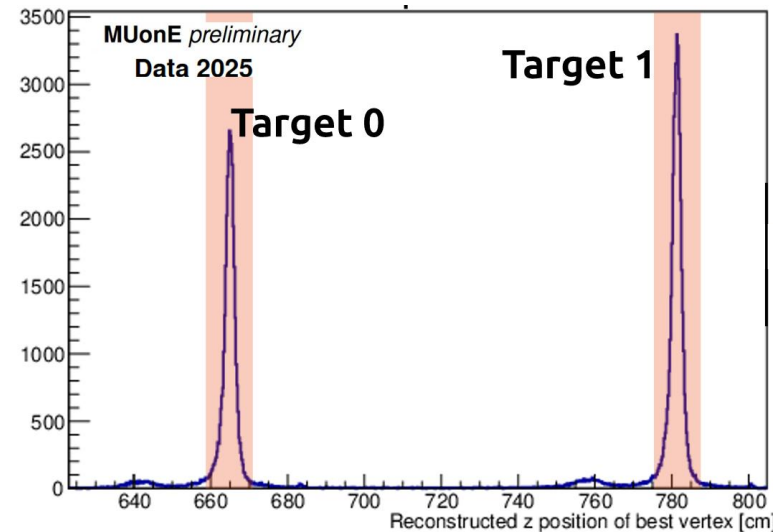

Not able to differentiate between μ and e^- in the region where $\theta_e < 5$ mrad

ECAL PID



Loose elastic selection

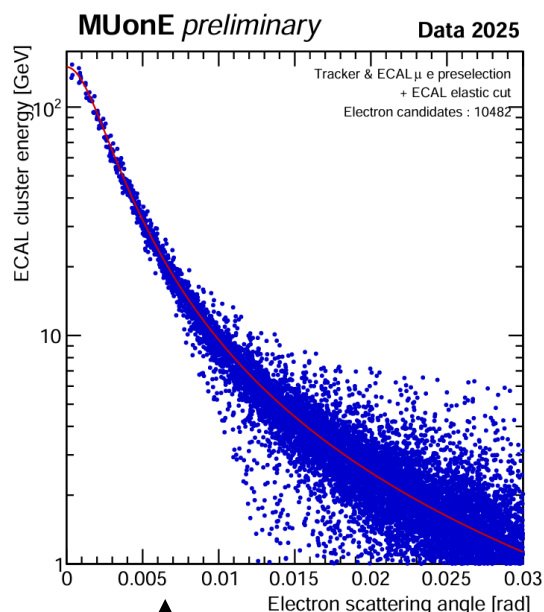
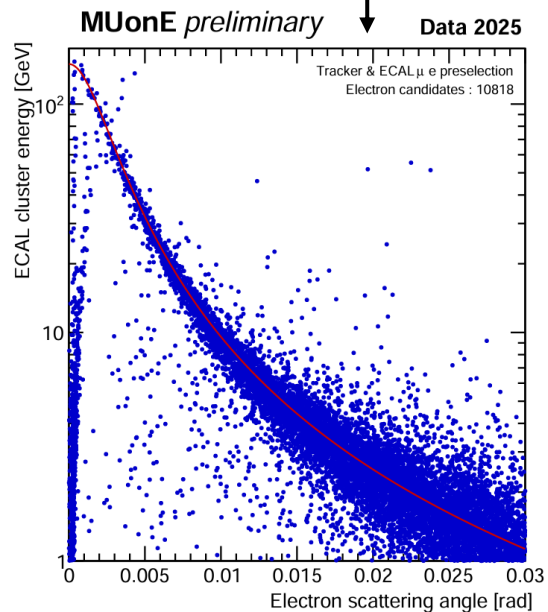

- ECAL energy > 1 GeV
- Matching between e^- track and ECAL cluster

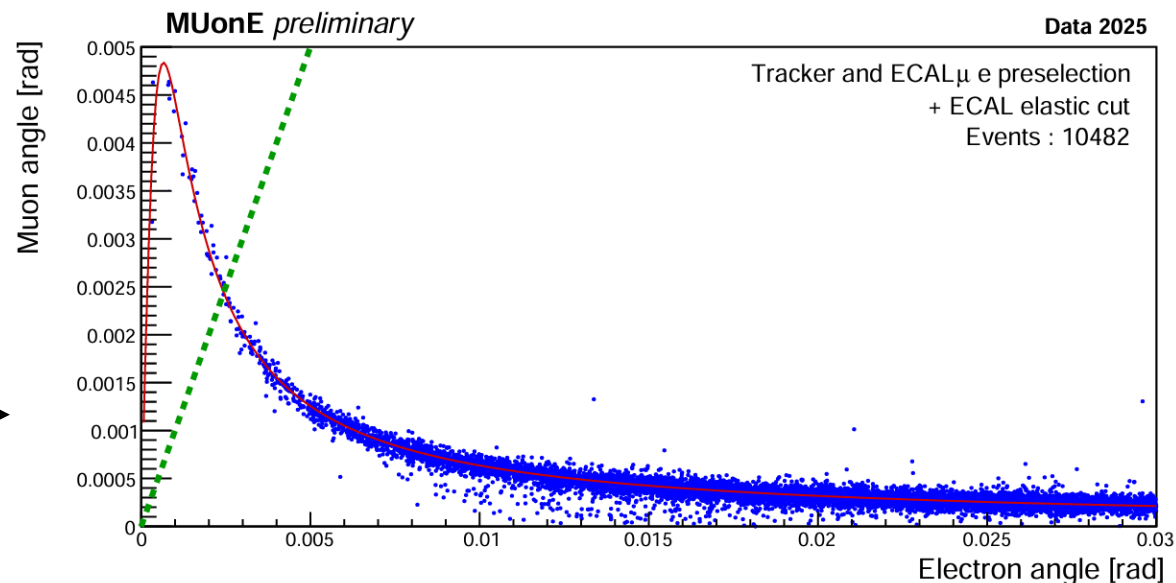
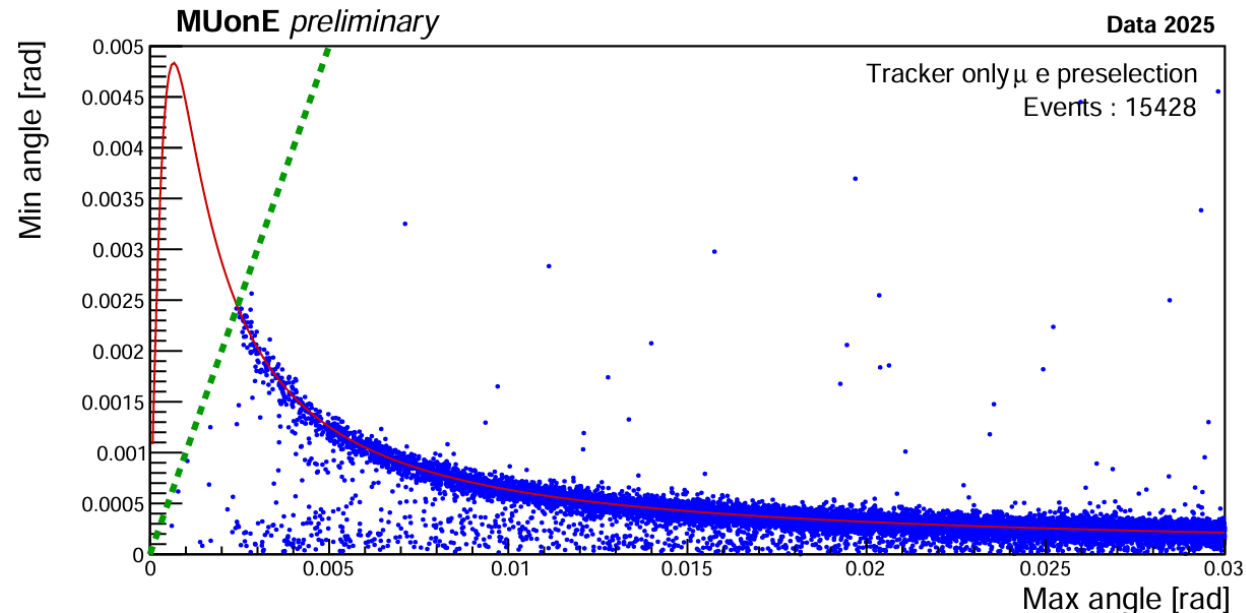

ECAL energy deposit correlation to θ_e

Muon Filter PID

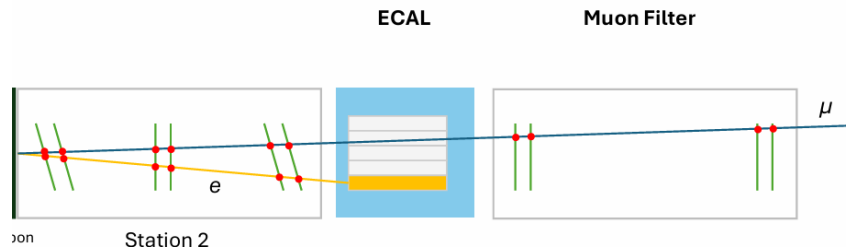

- Particle Identification is defined by matching the extrapolated tracks with hits in the Muon Filter.
- The muon track is tagged by a successful matching, while the electron track is requested not to match.

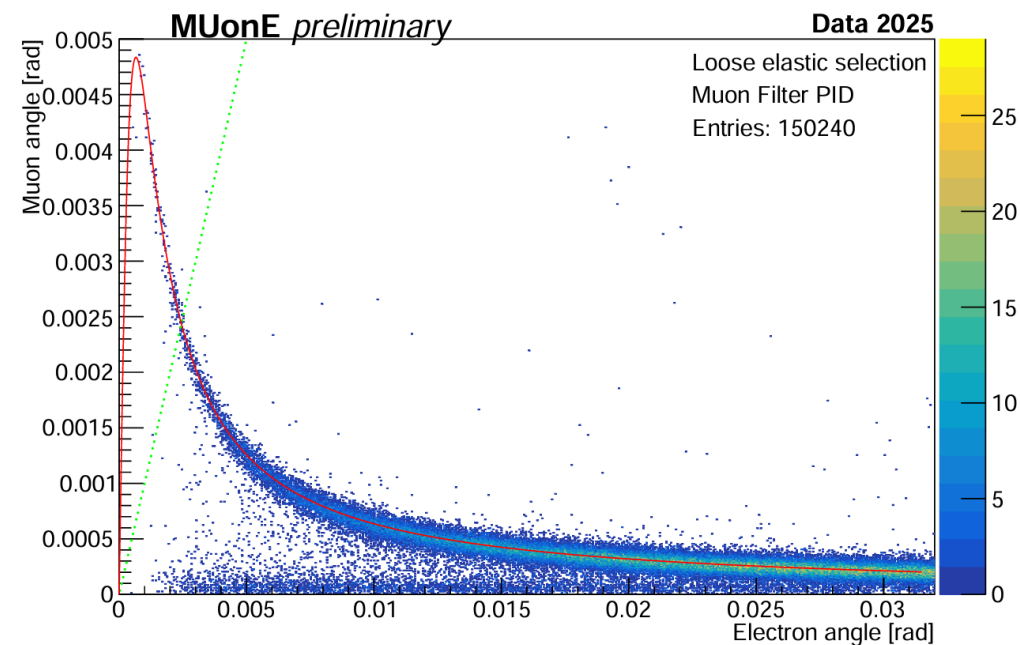
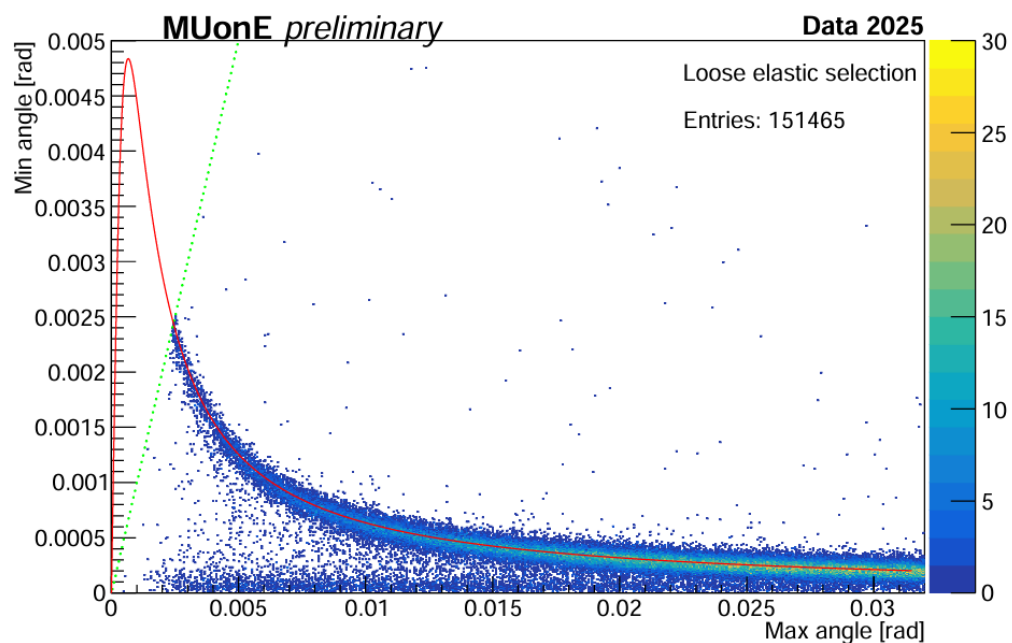

Summary

- The aim of MUonE is to provide an independent measurement of $\alpha_{\mu}^{HAD,LO}$
- 2025 test run was completed with 3 tracking stations, BMS and PID.
- Analysis of 2025 test run is ongoing , with aims to:
 1. Proof of principle measurement of $\Delta\alpha_{lep}(t)$
 2. Preliminary measurement of $\Delta\alpha_{had}(t)$ (~20% statistical error + similar systematic).
 3. Study systematic effects.
- 2025 data will be the basis for the full-scale experiment proposal (40 tracking stations + ancillary detectors) to be prepared during the CERN Long Shutdown 3.

Thank you for listening !



UNIVERSITY OF
LIVERPOOL

LEVERHULME
TRUST _____

Backup

Physics-inspired from the calculable contribution of lepton-pairs and top quarks at $t < 0$



$$q^2 = t < 0 \quad \Delta\alpha_{had}(t) = k \left\{ -\frac{5}{9} - \frac{4M}{3t} + \left(\frac{4M^2}{3t^2} + \frac{M}{3t} - \frac{1}{6} \right) \frac{2}{\sqrt{1 - \frac{4M}{t}}} \log \left| \frac{1 - \sqrt{1 - \frac{4M}{t}}}{1 + \sqrt{1 - \frac{4M}{t}}} \right| \right\}$$

M with dimension of mass squared, related to the mass of the fermion in the vacuum polarization loop
 k depending on the coupling $\alpha(0)$, the electric charge and the colour charge of the fermion

Low- $|t|$ behavior dominant in the MUonE kinematical range:

$$\Delta\alpha_{had}(t) = -\frac{1}{15} \frac{k}{M} t$$

for $t \rightarrow -0$

$$\Delta\alpha_{had}(t) = \frac{k}{3} \left(\log \frac{|t|}{M} - \frac{5}{3} \right)$$

for $t \rightarrow -\infty$

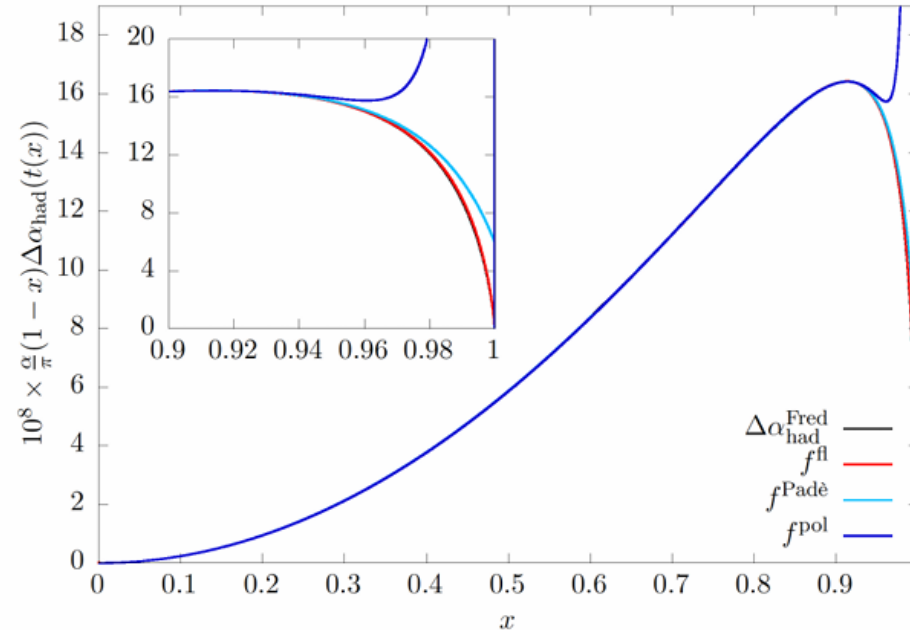

G.Abbiendi